

## Group 17 Propeller Shafts

**GENERAL:** This group contains information on the propeller shafts from the transmission to the differential, and the differential to the rear drive wheels. It also includes the axle shafts in the driving hub.

**SPECIFICS:** As applicable

...Axle Shaft

...Axle Shaft Bearings

...Propeller Shafts and Universal Joints







URGENT

ROUTINE

MANDATORY

INFORMATIONAL

# Service Bulletin

DATE February 13, 1976

NUMBER 2917 20002

ATTENTION: SERVICE MANAGERS

GROUP

T17

DESCRIPTION

This bulletin provides instructions for replacing the rear axle shafts on all transit coaches within the serial range as listed herein.

SUBJECT

NEW AXLE SHAFTS

COMPLIANCE

It is mandatory that the axle shafts and seals be changed as soon as possible upon receipt of the new parts. You are urged to comply to avoid any further damage to the coach.

MANPOWER

Estimated accomplishment time for one mechanic is 3 hours per coach to replace two axle shafts and seals.

MODEL(S)  
AFFECTED

ALL TRANSIT  
COACHES SERIAL  
00530 TO 00984

WARRANTY REIMBURSEMENT

FMC Motor Coach Division will allow labor reimbursement as outlined above upon receipt of a properly filled out Warranty Claim (RVD 69) for this axle shaft change.

PARTS FURNISHED

New axle shafts #5107657 and new seals #5100447-01 will be furnished on a no charge basis to all transit operators for replacement.

ACCOMPLISHMENT INSTRUCTIONS

See corrected pages T17-1 to T17-7 attached hereto for instructions to accomplish this bulletin.

F. J. ...

GROUP T-17  
 PROPELLER SHAFTS  
 TABLE OF CONTENTS

<u>PARAGRAPH</u>	<u>PAGE</u>
17-1 DESCRIPTION .....	(T) 17-2
a. General .....	(T) 17-2
b. Transmission-to-Differential Propeller Shaft .....	(T) 17-2
c. Differential-to-Axle Propeller Shaft .....	(T) 17-2
d. Rear Wheel Axle Shafts .....	(T) 17-2
17-2 TROUBLESHOOTING .....	(T) 17-2
17-3 REMOVAL/INSTALLATION .....	(U) 17-2
a. General .....	(T) 17-2
b. Transmission-to-Differential Propeller Shaft Removal .....	(T) 17-2
c. Transmission-to-Differential Propeller Shaft Installation .....	(T) 17-2
d. Differential-to-Axle Propeller Shaft Removal .....	(T) 17-4
e. Differential-to-Axle Propeller Shaft Installation .....	(T) 17-4
f. Rear Axle Shaft Removal .....	(T) 17-5
g. Rear Axle Shaft Installation .....	(T) 17-5
17-4 INSPECTION AND CLEANING .....	(T) 17-6
a. General .....	(T) 17-6
b. Propeller Shaft Inspection .....	(T) 17-6
c. Cleaning .....	(T) 17-6
17-5 GENERAL INFORMATION .....	(T) 17-7
a. General .....	(T) 17-7
b. Torque Requirements .....	(T) 17-7
c. Lubrication of Propeller Shaft Spicer/Beatings and Slip and Stub Yoke Splines .....	(T) 17-7
d. Replacing Axle Shaft Matched-Set Bearing Cones .....	(T) 17-7

BULLETIN 2917-20002

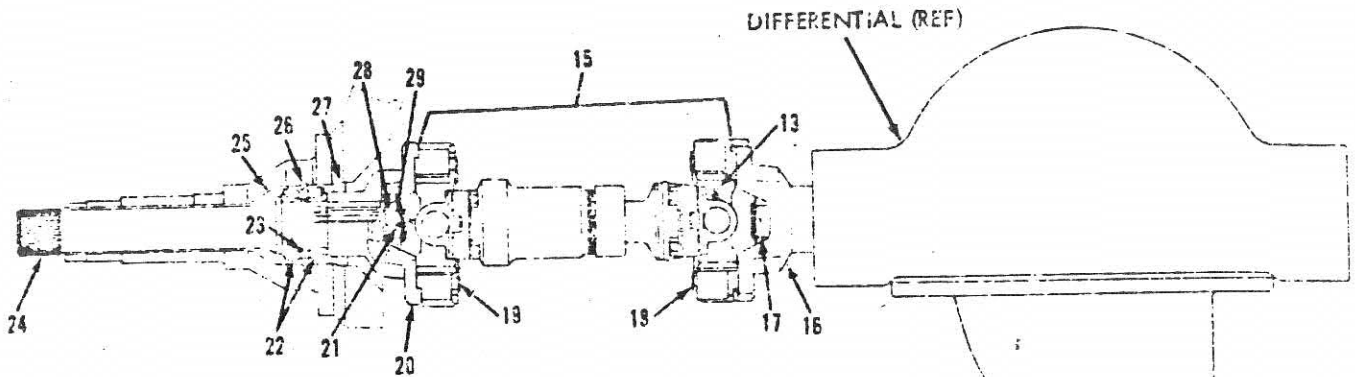

LEGEND

1. BOLT (4)
2. YOKE (INPUT)
3. NUT
4. LUBE FITTING
5. SHAFT ASSEMBLY (TRANSMISSION-TO-DIFFERENTIAL)
6. SPIDER AND BEARING ASSY
7. YOKE (STUD)
8. YOKE (SLIP)
9. BOLT (WITH LOCKWASHER) (4)
10. LUBE FITTING
11. SPIDER AND BEARING ASSY
12. COUPLING
13. LUBE FITTING
14. NUT (4)

NOTE: ITEMS 15 THRU 29 REFLECT THE LEFT SHAFT ASSEMBLY ONLY, THE RIGHT SHAFT (NOT SHOWN) CONTAINS THE SAME COMPONENTS.

15. SHAFT ASSEMBLY (DIFFERENTIAL-TO-REAR WHEEL SHAFT)
16. YOKE (OUTPUT)
17. NUT
18. BOLT (4)
19. BOLT (4)
20. YOKE
21. COTTER PIN (FOR NUT 29)
22. CONE WITH BEARINGS (2)
23. SPACER (BETWEEN CONES)
24. AXLE SHAFT
25. CUP (BEARING) (2)
26. RETAINING RING
27. GREASE SEAL
28. WASHER
29. NUT

\*DO NOT USE A HIGH PRESSURE GREASE GUN ON THESE FITTINGS.

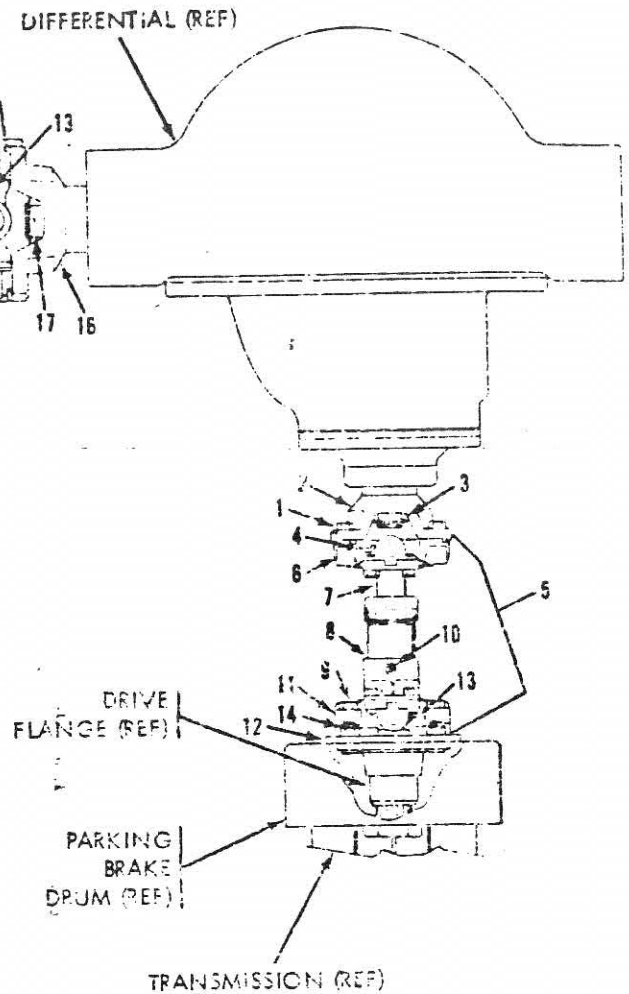

Figure 17-1. Propeller Shafts

## GROUP 17

### PROPELLER SHAFT

#### 17-1. DESCRIPTION

a. General (fig. 17-1). The coach drive line system contains three propeller shaft assemblies and axle shafts. Engine torque is transmitted from the transmission output shaft to the input yoke of the differential by a single propeller shaft assembly; two identical propeller shafts transmit the output torque from the differential to the rear wheel axle shafts. This group provides service instructions for the propeller shaft assemblies.

#### NOTE

For service information on the rear suspension system, refer to Group 6; for the differential, refer to Group 18. When applicable, other groups are referenced in the text. For information on part numbers and procurement of replacement parts, refer to Group 17 in the Repair Parts Catalog.

b. Transmission-to-Differential Propeller Shaft. The major components of the transmission-to-differential propeller shaft consist of spider bearing assemblies, a splined slip yoke, and a splined stub yoke. The spider/bearing on the aft end of the propeller shaft is the two-lock type with four mounting holes through which four bolts (with spring-lock washers) are inserted into the parking brake drum of the transmission output shaft. The forward spider/bearing is the four-wing type and contains threaded holes through which four attaching bolts hold the shaft to the differential input yoke.

#### NOTE

The bearings of each spider/bearing are lubricated via internal passages in the spider body which interconnect with a **LOW PRESSURE TYPE GREASE FITTING**. The meshed splines of the slip and stub yokes are lubricated by a grease fitting installed in the slip yoke housing.

c. Differential-to-Axle Propeller Shafts. The inboard spider/bearing of each differential-to-axle propeller shaft is attached by four bolts to the differential output yokes. The outboard spider/

bearings are attached to the yoke installed over the splined inboard ends of the axle by four bolts. Spider/bearings and slip and stub yokes are lubricated as described above.

d. Rear Wheel Axle Shafts. The rear wheel axle shaft meshes at the inboard side with the yoke of the propeller shaft leading to the differential. At the outboard side the axle shaft meshes with the rear wheel drive flange to turn the wheel. The inboard yoke is secured to the axle shaft with a nut and cotter pin (refer to Group 8 for wheels). The axle shaft rides within the spindle of the trailing arm and rotates on a matched set of bearings at the inboard end. The matched set of bearings is retained within the housing by a spacer and retaining rings. A press-fit grease seal fits in a groove on the inboard side of the trailing arm spindle. When replacing axle shaft bearings it is essential to use a matched set of bearings and a new spacer, retaining rings, and inboard seal.

#### 17-2. TROUBLESHOOTING

Instructions for troubleshooting the propeller shafts are contained in table 17-1. Prior to troubleshooting, make a preliminary visual inspection to assist in locating the problem.

#### 17-3. REMOVAL-INSTALLATION

a. General (fig. 17-1). Step-by-step instructions for replacement of the propeller shafts and components are provided in this section. Replacement parts should be procured from those listed in Group 17 of the Parts Catalog.

b. Transmission-to-Differential Propeller Shaft Removal. To remove the transmission-to-differential propeller shaft, proceed as follows:

(1) Remove four bolts and lockwashers attaching the aft end of shaft spider/bearing to the coupling on the parking brake drum; retain bolts.

(2) Support shaft assembly, and remove four bolts inserting through the yoke on the differential into the forward spider/bearing; retain bolts.

(3) Lower and remove shaft assembly.

c. Transmission-to-Differential Propeller

Table 17-1. Troubleshooting Propeller Shafts

Malfunction (symptoms)	Probable causes	Corrective action (remedies)
Vibration in propeller shaft	Defective bearings in spider bearing assembly	Replace assembly
	Loose bolts attaching aft spider/bearing assembly to coupling on transmission parking brake drum	Remove bolts, replace lockwashers (4) then re-install bolts and tighten
	Loose bolts attaching differential input yoke to fwd spider/bearing of propeller shaft	Remove bolts, wipe dry, reinstall, and tighten
	Foreign matter in shaft	Clean; refer to paragraph 17-4, c
	Transmission forward mounts failing, causing misalignment	Replace defective mounts; refer to Group 16
	Parking brake drum out of balance	Balance or replace drum; refer to Group 10
	Loose bolts attaching inboard and/or outboard spider/bearing ends of differential-to-axle propeller shaft yokes	Remove bolts, clean, reinstall and tighten
Excessive noise emitting from propeller shafts	Improper lubrication of spider/bearings	Lubricate; refer to paragraph 17-5, g
	Inboard bearings on axle shaft in spindle defective	Replace; refer to paragraphs 17-5f and g.

Shaft Installation. To install the transmission-to-differential shaft assembly, proceed as follows:

(1) Position shaft in place between the transmission and differential with the splined slip yoke containing the grease fitting to mate with the coupling on the parking brake drum.

(2) Using four new lockwashers and four bolts retained from step b.(1), attach shaft spider bearing to coupling. Tighten bolts evenly.

(3) Using bolts retained from step b.(2), wipe dry of all lubricant and attach differential input yoke to the spider bearing on shaft. Tighten bolts evenly to a torque of 25 to 30 foot pounds.

d. Differential-to-Axle Propeller Shaft Removal. To remove the differential-to-axle shaft, proceed as follows:

(1) Remove four bolts attaching spider bearing to yokes on wheel axle shaft; retain bolts.

(2) Remove four bolts attaching spider bearing to output yoke on differential assembly; retain bolts

(3) Lower and remove propeller shaft assembly.

c. Differential-to-Axle Propeller Shaft Installation. To install the differential-to-axle shaft as-

sembly proceed as follows:

(1) Position shaft in place between the axle yoke and differential with the splined slip yoke containing the grease fitting to mate with the yoke on the axle shaft end.

(2) Using four bolts retained from step d.(1), wipe dry of all lubricant and attach outboard shaft spider/bearing to yoke on axle shaft. Tighten bolts evenly to a torque of 25 to 30 foot pounds.

(3) Using bolts retained from step d.(2), wipe dry of all lubricant and attach differential output yoke to the inboard spider/bearing on shaft. Tighten bolts evenly to a torque of 25 to 30 foot pounds.

f. Rear Axle Shaft Removal. To remove rear axle shaft, proceed as follows:

(1) Remove four bolts attaching propeller shaft spider bearing yoke on rear wheel axle shaft and lower end of propeller shaft to allow inboard movement of axle shaft; retain bolts.

(2) Remove center pin, nut and washer from inboard end of axle shaft. Mark yoke position on shaft to aid in reinstallation, then remove splined yoke; retain washer, nut and yoke.

(3) Remove wheel cover from outboard rear wheel.

(4) Remove hub cap.

(5) Remove eight nuts and lockwashers attaching the drive flange to drive studs on hub, then remove drive flange; retain nuts and drive flange (if new lockwashers are available, discard old).

(6) Use bearing puller (with large jaws) and remove press-fit grease seal from inboard end of axle shaft.

#### NOTE

During following step, do not rotate bearing puller until the back of the bearing cup can be inspected to determine at what degree the identification markings have been positioned. Note this position for use during reinstallation procedures. This is important as cups do not rotate and consequently the load is concentrated in a relatively small area. By rotating the cups 90 degrees during reinstallation, a new load zone is established and the life of the cup (and bearing when reused) is prolonged.

(7) Use bearing puller (with large jaws) and remove inboard bearing cone and cup surrounding the axle shaft from the I.D. of spindle. Retain cup (and bearing cone if it is to be reused).

(8) Remove bearing-cone spacer; retain.

(9) Use retaining pliers (internal type) and insert into holes in the two lugs on the retaining ring gapped ends. The retaining ring is seated in a groove and holds the inner bearing cone and cup in the spindle. Compress retaining ring until free of groove edges, then pull out ring; retain ring.

#### NOTE

As shaft is removed from spindle during following step, do not rotate until the back of the bearing cup can be inspected to determine at what degree the identification markings have been positioned. Note this position for use during reinstallation procedures. This is important as cups do not rotate and consequently the load is concentrated in a relatively small area. By rotating the cups 90 degrees during reinstallation in the spindle, a new load zone is established and the life of the cup (and bearing when reused) is prolonged.

(10) Install protector on splines of outboard end of axle shaft. Use lead or soft-headed hammer to tap shaft and torque shaft, bearing cone, and press-in bearing cup out the inboard side of the trailing arm spindle. Check cup positioning per above NOTE. Lower and remove shaft, then remove bearing cone and cup from O.D. of shaft. Retain shaft and cup (and bearing cone if it is to be reused).

(11) Remove grease from I.D. of spindle cavity and flush or wipe clean, making sure no foreign material remains in internal groove for the retaining ring.

(12) Clean and repack matched bearing cone set, as required; refer to paragraph 17-5.

g. Rear Axle Shaft Installation. To install rear axle shaft, bearings, grease seal and yoke, proceed as follows:

(1) Lubricate spindle outboard bearing cavity area I.D. with sufficient grease (NLG1 Grade 2) to form a dam around the bearing mount areas to hold the grease in place and insert axle shaft.



into I.D. of spindle so that splines on outboard ends of shaft just clear the outboard end of spindle.

### *Caution*

The two bearing cones for the axle shaft are a matched set and if one is defective it is necessary to replace both to ensure equal load distribution and wear.

(2) Insert repacked bearing cone in cup and position assembly to enter the I.D. of spindle 90 degrees clockwise from its previous position as noted in step f.(9), and with back face of cup inboard and bearing cone protruding out of cup toward outboard end of shaft. Install repacked outboard bearing cone and cup assembly by using suitable device to press assembly in position around the axle shaft in I.D. of the spindle.

(3) Use retaining ring pliers (internal type) and insert into holes in the two lugs on the retaining ring gapped ends. Compress ring and insert over axle shaft and seat in the grooves in spindle I.D. just inboard of previously installed bearing cup.

(4) Install bearing cone spacer over shaft and insert into I.D. of spindle to contact face of the bearing cup.

(5) Insert repacked bearing cone in cup and position assembly to enter the I.D. of spindle 90 degrees clockwise from its previous position as noted in preceding step f.(6), and with back face of cup outboard and bearing cone protruding out of cup toward inboard end of shaft. Then install repacked inboard bearing cone and cup by using suitable device to press cup and bearing assembly in position around the axle shaft in spindle I.D.

(6) Pack inboard bearing cavity areas extending inboard to grease seal groove in spindle with grease (NLGI Grade 2).

(7) Install new grease seal in inboard groove in spindle; seal may be driven in with a wooden block tapped with a hammer or with an arbor press.

(8) Lightly lubricate threads of drive flange mounting studs with threadlube.

(9) Install new O-ring in drive flange groove.

(10) Secure drive flange with eight washers and nuts; tighten nuts 39 to 43 foot pounds.

(11) Install hub cap in flange over end of outboard end of axle shaft.

(12) Install wheel cover.

(13) Install yoke on inboard splined end of axle shaft in position marked during removal, using care not to damage grease seal.

(14) Secure yoke <sup>150</sup> on axle shaft end with washer and nut. Torque nut to ~~8~~ foot pounds to seat bearings, then back nut off 1/6 to 1/4 turn and install new cotter pin.

(15) Align propeller shaft spider/bearing with yoke mount holes and attach with four bolts (wipe bolts dry of all lubricant) retained during removal; torque bolts 25 to 30 foot pounds.

#### 17-4. INSPECTION AND CLEANING

a. General. The following procedures provide information necessary for inspection and cleaning of the propeller shafts.

##### b. Propeller Shaft Inspection (fig. 17-1).

(1) With the engine shut down, parking brakes on, and the wheels securely blocked against movement, inspect the propeller shafts and yokes for evidence of loose parts, contamination, excessive play, cracks, and damaged parts. Clean foreign matter from parts with water and/or compressed air, as necessary. Replace damaged parts.

(2) Check all fasteners for secure mounting using torque wrench, where applicable.

c. Cleaning. Thorough cleaning of the propeller shaft exterior is an essential prelude to any close inspection, in order that the existence and extent of material defects can be determined. It is recommended that the propeller shafts be cleaned periodically to remove mud, dirt, undercoating or rust proofing accumulations which could cause vibration. Conventional drive-in, do-it-yourself, high pressure spray type washing will normally provide sufficient cleaning. Care must be taken not to direct spray pressure on grease seals. Direct the spray from under the coach up into hard-to-see spots. Do not spray areas other than the propeller shafts, differential, or transmission. Spraying with a soap solution should be followed by a water rinse to remove all traces of the solution. Following washing, apply lubricant to grease fittings (use low pressure grease gun), if needed; refer to paragraph 17-5.2.

17-5. GENERAL INFORMATION

a. General. This section contains general information related to data contained in the previous paragraphs.

b. Torque Requirements. Torque requirements for the propeller shafts are specified in table 17-2.

c. Lubrication of Propeller Shaft Spider/Bearings and Slip and Stub Splines. The bearings of each spider/bearing are supplied lubricant via internal passages in the spider body which interconnect with a low pressure type grease fitting. The meshed splines of the slip and stub yokes are supplied lubricant from a grease fitting installed in the slip yoke housing. Lubricate with grease, NLG1 Grade 2. Apply grease to fittings with a low pressure hand-type grease gun or a high pressure gun with a low pressure adapter only.

*Caution*

Do not use a high pressure grease gun on spider/bearing grease fittings, as it will rupture the cork seals.

d. Repacking Axle Shaft Matched-Set Bearing Cones. To repack axle shaft bearing cones, proceed as follows:

- (1) Using Croft T310 bearing packer, place small end of bearing cone to press down on tool cup.
- (2) Position packer handle cone on top of bearing.
- (3) Press down on handle to force lube through bearing recesses.

NOTE

With bearing cone in packer, apply only moderate pressure on handle to ensure even grease flow into bearing recesses.

- (4) Lift handle and slide bearing out over edge of bearing cup.
- (5) Repeat steps (1) through (4) for opposite bearing cone.

(EVERY 3000 MILES)

Table 17-2. Torque Requirements

Part secured	Attaching part(s)	Torque (foot-pounds)
Yoke to fwd spider/bearing on transmission-to-differential propeller shaft	Bolts (4), dry, non-lubricated	25 to 30
Differential and axle yokes to spider/bearings on differential-to-axle propeller shafts	Bolts (4 on each end) dry, non-lubricated	25 to 30
Drive flange to drive studs on hub	Nuts (4) and washers	39 to 43
Yoke to splined inboard end of axle shaft	Nut and washer	150 Refer to paragraph 17-3, g., step (14)