

The following catalog has gaps in its page numbers, or doesn't have any numbers. We have chosen to leave the page numbering in the order that Acrobat assigns it.

FICHE LOCATION

ILLUSTRATION

1 A3	*****	DATA TABLE
1 A11	*****	CARBURETOR PARTS GROUP
1 B5	*****	CONTROL ASSEMBLY GROUP 300-0859
1 B1	*****	CONTROL-IGNITION GROUP
1 A9	*****	CRANKSHAFT, FLYWHEEL, CAMSHAFT & PISTON GROUP
1 A5	*****	CYLINDER BLOCK GROUP
1 A13	*****	FUEL PUMP GROUP (ELECTRIC)
1 A11	*****	FUEL SYSTEM & EXHAUST GROUP
1 B1	*****	FUEL TANK GROUP
1 A7	*****	GEAR COVER & OIL BASE GROUP
1 B7	*****	GENERATOR GROUP
1 A9	*****	HOUSING & GOVERNOR GROUP
1 B3	*****	HOUSING GROUP
1 A7	*****	OIL SYSTEM GROUP
1 B3	*****	REMOTE CONTROL GROUP
1 B5	*****	REMOTE STARTING CONTROL GROUP - OPTIONAL
1 A13	*****	VACUUM SPEED BOOSTER GROUP

This catalog applies to the standard NH Home Standby Power Sets as listed below. Parts are arranged in groups of related items. Each illustrated part is identified by a reference number corresponding to the same reference number below the illustration. Parts illustrations are typical. Using the MODEL and SPEC NO. from the nameplate select parts from this catalog that apply to your set. Unless otherwise mentioned in the description, parts are interchangeable between models. Right and left sides are determined by FACING the engine end (front).

PLANT DATA TABLE

MODEL AND SPEC	ELECTRICAL DATA				
	WATTS	VOLTS	HERTZ	WIRE	PHASE
6.5NH-3CR/*	6500	120/240	60	**	1

- * - The Specification Letter advances (A to B, B to C, etc.) with manufacturing changes.
 - ** - Plant is reconnectable for 120 volt, 2 wire; 240 volt, 2 wire or 120/240 volt, 3 wire service.
- The letter R in MODEL and SPEC denotes electric start with start-stop at both the set and the remote control.

NOTE: Hertz is a unit of frequency equal to one cycle per second.

REF. NO.	PART NO.	QTY. USED	PART DESCRIPTION
1	110-1964	1	Block Assembly, Cylinder (Includes Parts Marked *)
2	123-0787	1	Cap, Breather
3	123-0645	1	*Tube, Breather
4	123-0865	1	Baffle, Breather Tube
5	110-1624	2	Cover, Valve Compartment
6	110-1720	2	Gasket, Valve Cover
7	517-0048	1	*Plug, Camshaft Expansion
8	520-0736	5	*Stud, Rear Bearing Plate Mounting
9	110-1731	2	Gasket, Cylinder Head
10	110-1905	1	Head, Cylinder - (2) RH
11	110-1906	1	Head, Cylinder - (1) LH
12	*BEARING, CRANKSHAFT - REAR		
	101-0420	1	Standard
	101-0420-02	1	.002" Undersize
	101-0420-10	1	.010" Undersize
	101-0420-20	1	.020" Undersize
	101-0420-30	1	.030" Undersize
13	104-0575	2	£*Washer, Crankshaft Bearing Thrust
14	101-0415	1	*Gasket, Bearing Plate
15	101-0439	1	*Plate, Rear Bearing (Excludes Bearing - Includes Pins)
16	101-0405	2	*Bearing, Camshaft Front & Rear (Precision)
17	509-0041	1	*Seal, Bearing Plate
18	516-0072	4	*Pin, Main Bearing Stop
19	104-0091	5	*Nut, Bearing Plate Stud
20	526-0063	2	Washer (Copper), Valve Compartment Cover
21	120-0680	1	*Tube, Crankcase Oil
22	110-1718	2	Valve, Intake
23	110-1719	2	Valve, Exhaust (Stellite)
24	*INSERT, EXHAUST VALVE SEAT (STELLITE)		
	110-1716	2	Standard
	110-1716-02	2	.002" Oversize
	110-1716-05	2	.005" Oversize
	110-1716-10	2	.010" Oversize
	110-1716-25	2	.025" Oversize
25	*INSERT, INTAKE VALVE SEAT		
	110-1933	2	Standard
	110-1933-02	2	.002" Oversize
	110-1933-05	2	.005" Oversize
	110-1933-10	2	.010" Oversize
	110-1933-25	2	.025" Oversize

REF. NO.	PART NO.	QTY. USED	PART DESCRIPTION
26	110-1939	4	*Guide, Valve
27	110-0539	4	Spring, Valve
28	110-0639	8	Lock, Valve & Spring Retaining
29	TAPPET, VALVE		
	115-0006	4	Standard
	115-0006-05	4	.005" Oversize
30	110-0904	2	Rotocap, Exhaust Valve (Gasoline Fueled)
31	110-0893	2	Washer, Retainer - Intake Valve Spring (2 used on Exhaust Valve on Gas- Gasoline & Gas Only Models)
32	123-0315	1	Valve, Breather
33	154-1424	2	Insert, Exhaust Port
34	526-0250	20	Washer, Flat - Cylinder Head Stud
35	110-0068	2	*Gasket, Valve Guide (Intake)
36	STUD, CYLINDER HEAD MOUNTING		
	520-0717	8	3/8 x 1-7/8"
	520-0715	8	3/8 x 2-3/4"
	520-0716	4	3/8 x 2-1/2"
37	104-0091	20	Nut, Flange - Cylinder Head Stud
38	800-0011	2	Screw, Hex Head (1/4-20 x 2") Valve Box Cover
39	166-0519	1	Bracket, Timing
40	104-0776	As Req.	*Shim (.005"), Crankshaft Thrust
41	*BEARING, CRANKSHAFT - FRONT		
	101-0432	1	Standard
	101-0432-02	1	.002" Undersize
	101-0432-10	1	.010" Undersize
	101-0432-20	1	.020" Undersize
	101-0432-30	1	.030" Undersize
42	526-0251	5	*Washer, Flat (3/8") - Bearing Plate Stud

* - Included in Cylinder Block Assembly.
£ - Use one only with rear bearing on units with flange
type front bearing.

GEAR COVER AND OIL BASE GROUP

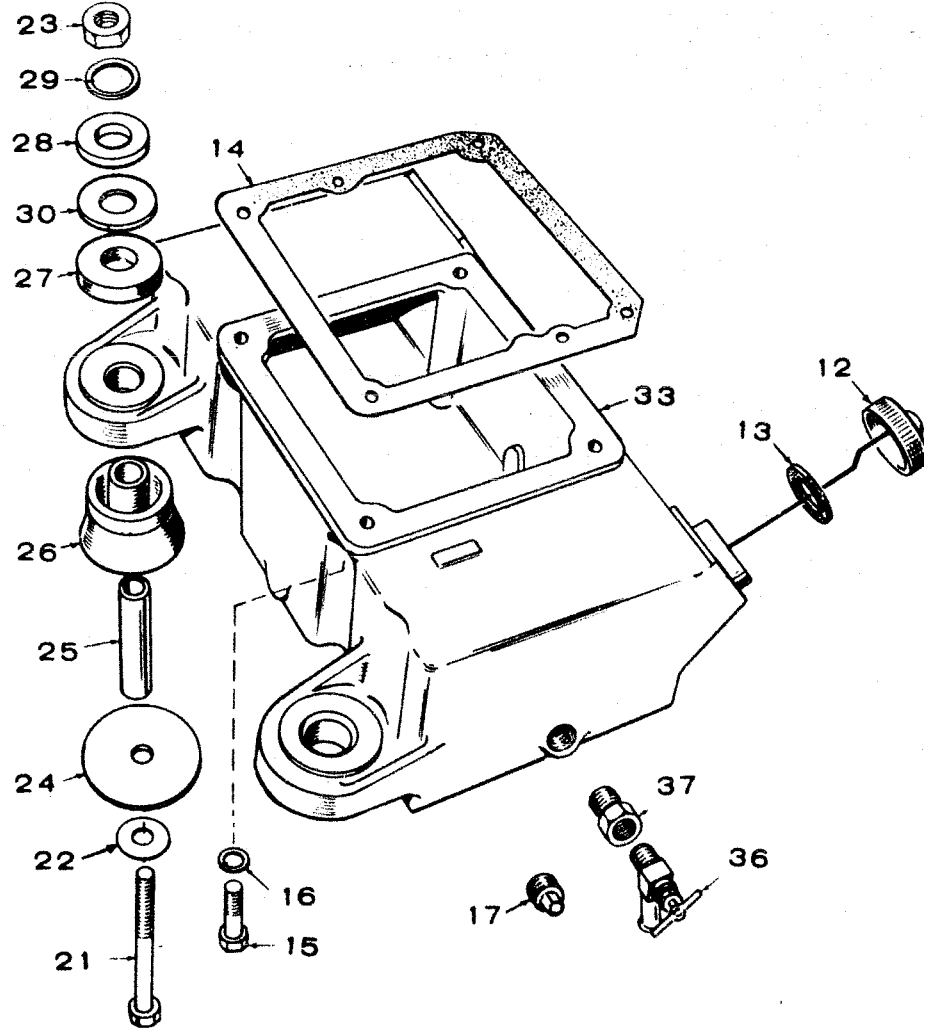
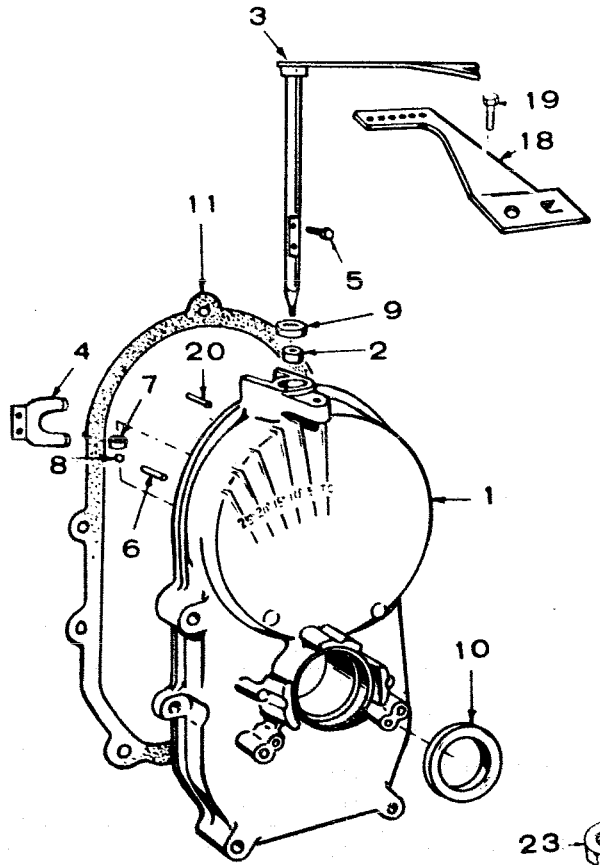

REF. NO.	PART NO.	QTY. USED	PART DESCRIPTION
1	103-0329	1	Cover Assembly, Gear - Includes Parts Marked *
2	510-0013	1	*Bearing
3	150-1180	1	*Shaft and Arm
4	150-1187	1	*Yoke, Shaft
5	815-0046	2	*Screw, Pan Head (8-32 x 3/8")
6	516-0130	1	*Pin, Dowel
7	510-0008	1	*Bearing
8	510-0014	1	*Ball, Bearing
9	509-0008	1	*Seal, Oil
10	509-0040	1	*Seal, Gear
11	103-0011	1	Gasket, Cover
12	123-0489	1	Indicator & Cap, Oil
13	123-0191	1	Gasket, Oil Cap
14	102-0646	1	Gasket, Base
15	800-0051	4	Screw, Hex Head (3/8-16 x 1-1/4")
16	850-0050	4	Washer, Lock (3/8)
17	505-0056	1	Plug
18	150-1073	1	Extension, Governor Arm
19	815-0181	1	Screw, Hex Head (10-32 x 1/2")
20	516-0011	2	Pin, Dowel (5/16 x 1-1/8")

REF. NO.	PART NO.	QTY. USED	PART DESCRIPTION
21	800-0082	4	Screw, Hex Head (7/16-14 x 3-3)
22	526-0032	4	Washer, Flat (29/64 I.D. x 7/8 O.D. x 1/16")
23	862-0004	4	Nut, Hex (7/16-14)
24	526-0182	8	Washer, Flat (29/64 I.D. x 3-1/4 O.D. x 1/8")
25	402-0290	4	Spacer
26	402-0284	4	Cushion, Mount
27	402-0282	4	Snubber, Mount
28	526-0014	4	Washer, Flat (29/64 I.D. x 1-1/2 O.D. x 1/8")
29	850-0055	4	Washer, Lock (7/16)
30	526-0198	As Req.	Washer, Flat (5/8 I.D. x 1-1/2 O.D. x 1/16")
31	800-0032	4	Screw, Hex Head (5/16-18 x 1-3/4")
	800-0034	1	Screw, Hex Head (5/16-18 x 2-1/4")
32	526-0065	5	Washer, Flat - Copper
33	102-0672	1	Base, Oil

* - Parts Included in Gear Cover Assembly.

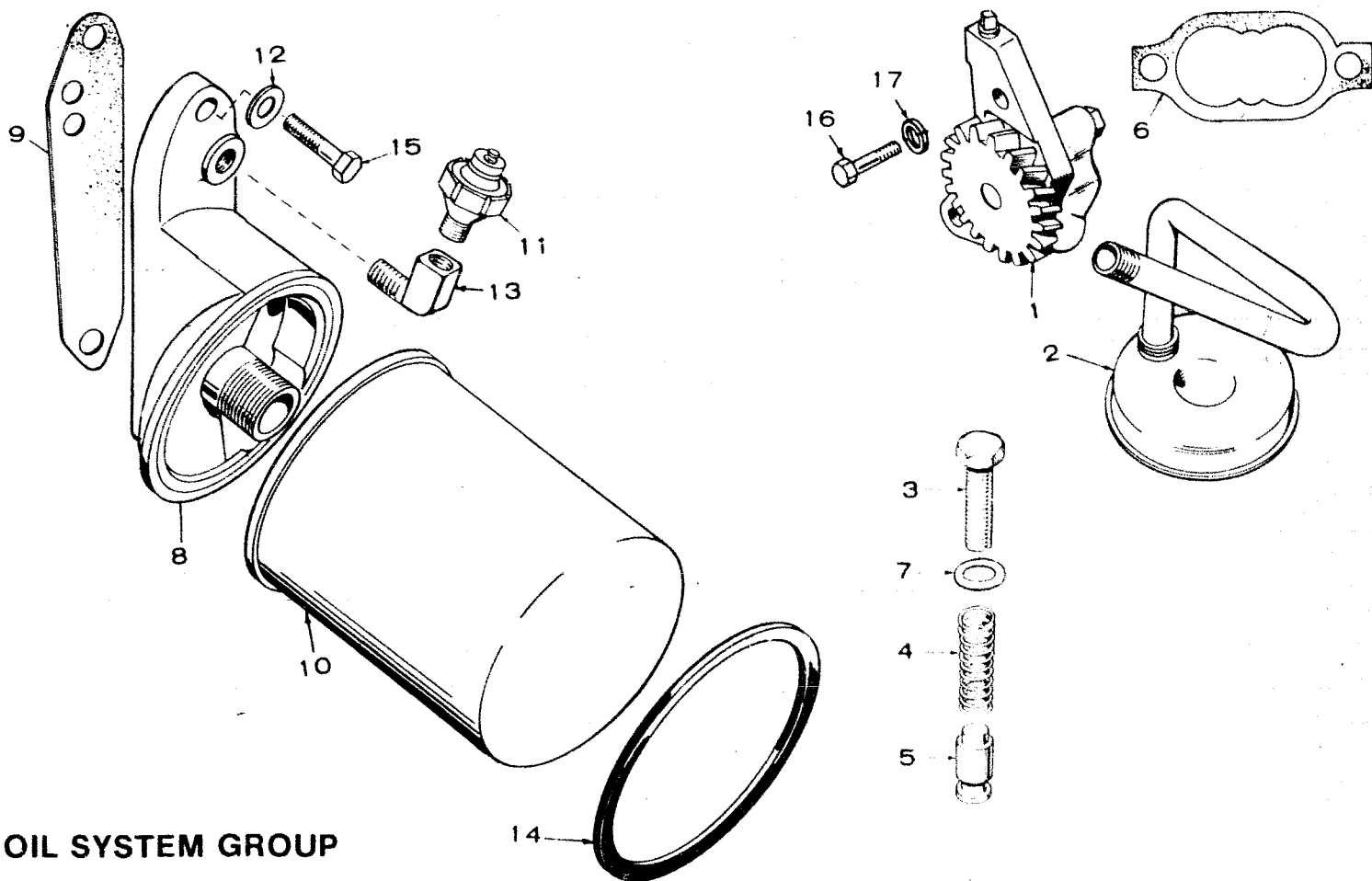

OIL SYSTEM GROUP

REF. NO.	PART NO.	QTY. USED	PART DESCRIPTION
1	120-0491	1	Pump, Oil (Components Not Sold Separately)
2	120-0400	1	Intake, Oil Pump - Includes Cup, Screen & Pipe
3	801-0050	1	Screw, Hex Head Cap (3/8-24 x 1") - Oil By-Pass
4	120-0140	1	Spring, By-Pass Valve
5	120-0398	1	Valve, By-Pass
6	120-0161	1	Gasket Kit, Oil Pump
7	526-0066	1	Washer, Oil Pressure Relief Valve Adjusting Screw
8	122-0320	1	Adapter, Oil Filter

REF. NO.	PART NO.	QTY. USED	PART DESCRIPTION
9	122-0321	1	Gasket, Adapter
10	122-0323	1	Filter, Oil (Includes Gasket)
11	309-0237	1	Switch, Low Oil Pressure
12	526-0065	2	Washer (Copper), Adapter Mounting
13	502-0196	1	Elbow, Street (90°)
14	122-0347	1	Gasket, Filter
15	800-0028	2	Screw, Hex Head Cap (5/16-18 x Adapter Mounting)
16	800-0007	2	Screw, Hex Head Cap (1/4-20 x 1" Oil Pump Mounting)
17	850-0040	2	Washer, Lock (1/4")

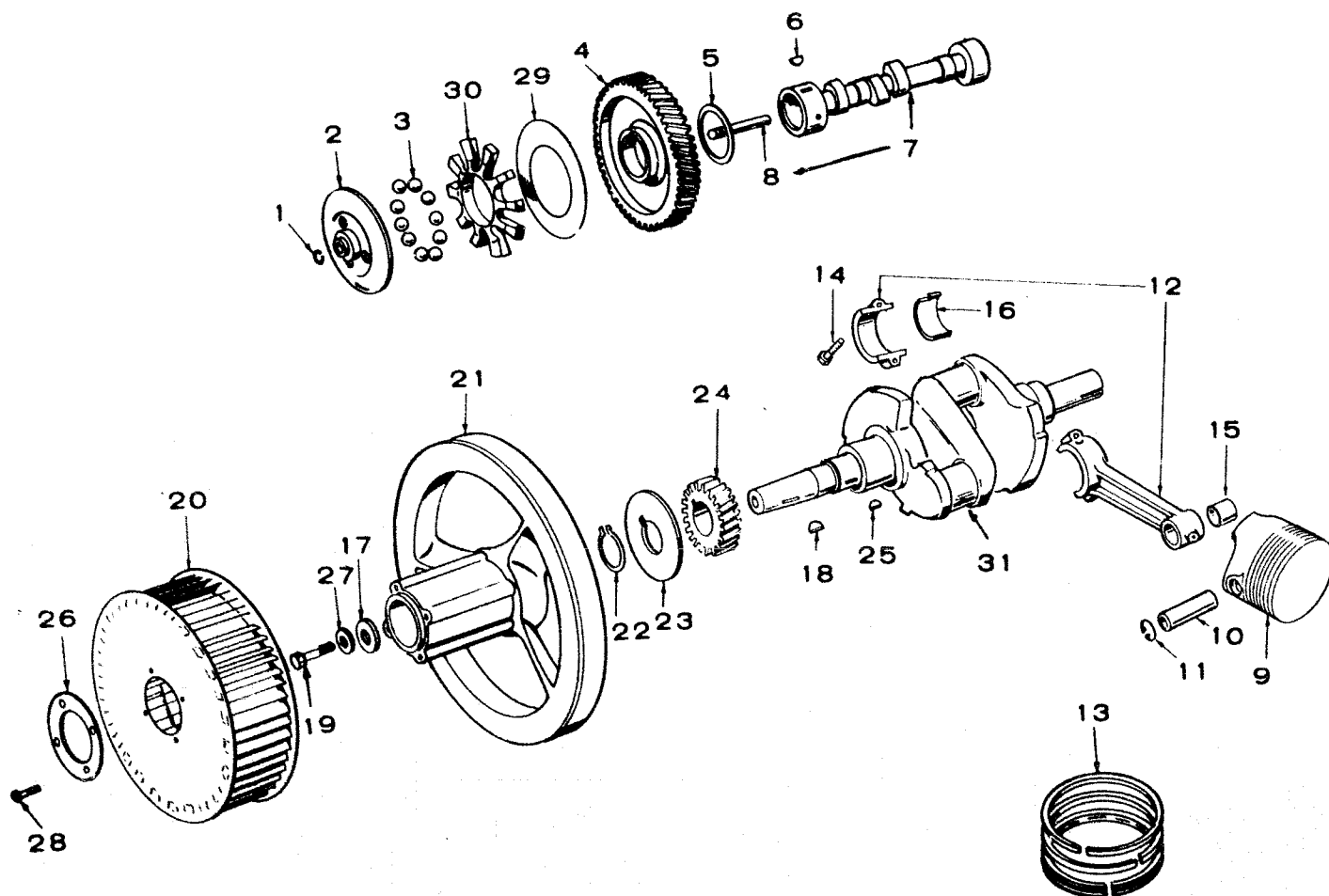

CRANKSHAFT, FLYWHEEL, CAMSHAFT AND PISTON GROUP

REF. NO.	PART NO.	QTY. USED	PART DESCRIPTION
1	150-0078	1	Ring, Camshaft Center Pin
2	150-0612	1	Cup, Governor
3	510-0015	10	Ball, Fly - Governor
4	105-0332	1	Gear, Camshaft
5	105-0004	1	Washer, Camshaft Gear Thrust
6	515-0001	1	Key, Camshaft Gear Mounting
7	105-0309	1	Camshaft (Includes Center Pin)
8	150-0075	1	Pin, Center - Camshaft
9	PISTON AND PIN (INCLUDES RETAINING RINGS)		
	112-0141	2	Standard
	112-0141-05	2	.005" Oversize
	112-0141-10	2	.010" Oversize
	112-0141-20	2	.020" Oversize
	112-0141-30	2	.030" Oversize
	112-0141-40	2	.040" Oversize
10	112-0112	2	Pin, Piston
11	518-0294	4	Ring, Piston Pin Retaining
12	114-0203	2	Rod, Connecting (Includes Bushing & Bolts Marked *)
13	RING SET, PISTON		
	Gasoline		
	113-0165	2	Standard
	113-0165-05	2	.005" Oversize
	113-0165-10	2	.010" Oversize
	113-0165-20	2	.020" Oversize
	113-0165-30	2	.030" Oversize
	113-0165-40	2	.040" Oversize

REF. NO.	PART NO.	QTY. USED	PART DESCRIPTION
14	805-0010	4	*Bolt, Place - Connecting Rod Cap
15	114-0036	2	*Bushing, Piston Pin - Connecting Rod
16	BEARING HALF, CONNECTING ROD		
	114-0188	4	Standard
	114-0188-02	4	.002" Undersize
	114-0188-10	4	.010" Undersize
	114-0188-20	4	.020" Undersize
	114-0188-30	4	.030" Undersize
17	526-0017	1	Washer, Wheel Mounting
18	515-0002	1	Key, Wheel Mounting
19	104-0170	1	Screw, Wheel Mounting
20	134-2130	1	Wheel, Blower
21	104-0739	1	Flywheel
22	518-0014	1	Lock, Crankshaft Gear Washer
23	104-0043	1	Washer, Crankshaft Gear Retaining
24	104-0032	1	Gear, Crankshaft
25	515-0001	1	Key, Crankshaft Gear Mounting
26	134-0911	1	Plate, Blower Wheel
27	850-0055	1	Washer, Lock (7/16)
28	821-0018	4	Screw, Hex Locking Head (1/4 x 5/8") Blower Wheel Mount
29	150-0077	1	Plate, Flyball
30	150-1257	1	Spacer, Flyball
31	104-0731	1	Crankshaft

* - Parts included with Connecting Rod.

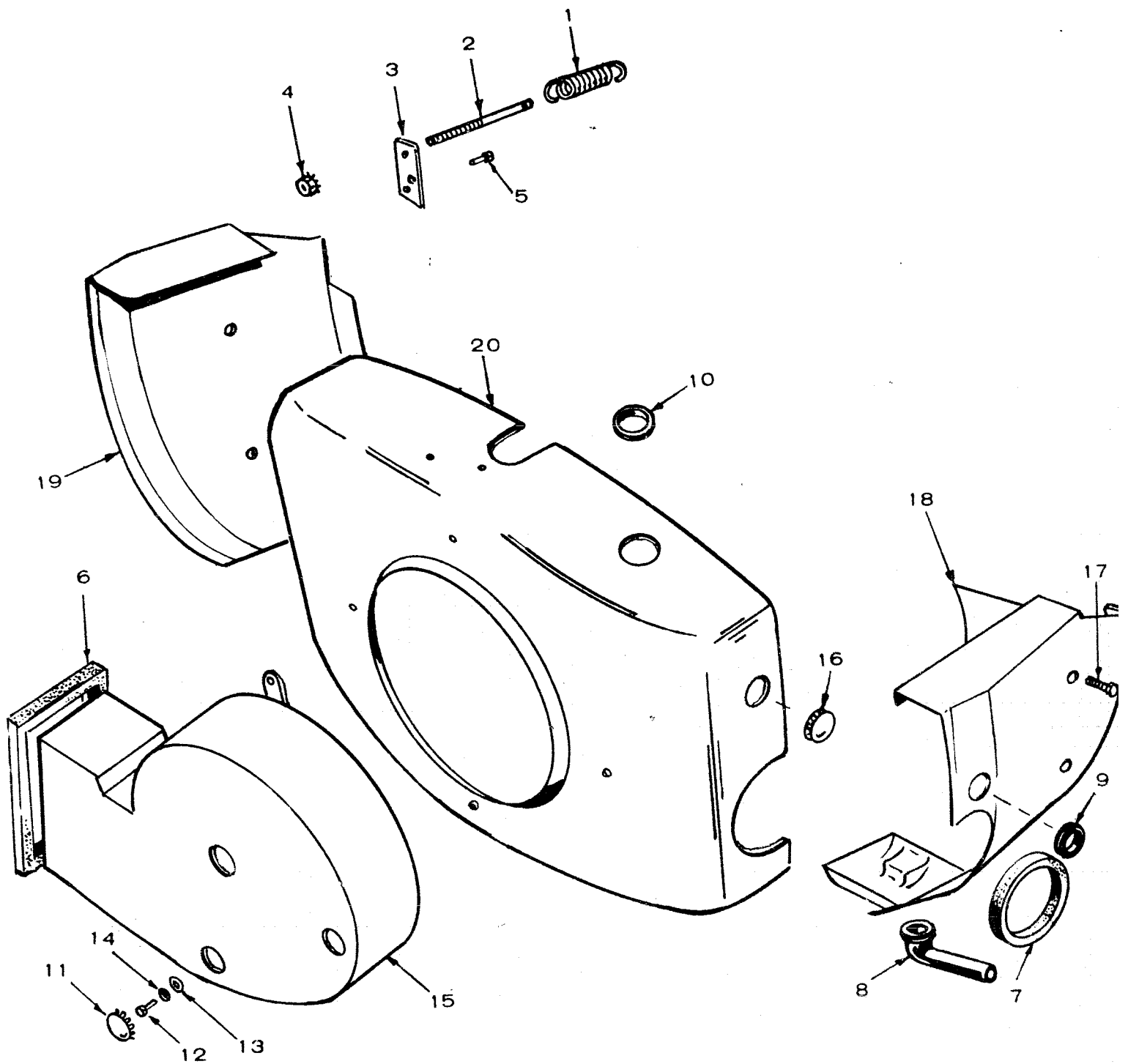

HOUSING AND GOVERNOR GROUP

REF. NO.	PART NO.	QTY. USED	PART DESCRIPTION	REF. NO.	PART NO.	QTY. USED	PART DESCRIPTION
1	150-0098	1	Spring, Governor	11	517-0021	2	Button, Plug
2	150-1331	1	Stud, Speed Adjustment	12	800-0002	4	Screw, Hex Head (1/4-20 x 3/8")
3	134-2321	1	Bracket, Speed Stud	13	526-0015	4	Washer, Flat (1/4)
4	870-0131	1	Nut, Speed Adjustment	14	853-0013	4	Washer, Lock (1/4)
5	821-0004	2	Screw, Hex Head (10-32 x 5/16)	15	134-2361	1	Scroll, Air
6	134-2231	1	Seal, Air Scroll	16	517-0035	1	Button, Plug
7	155-1252	1	Seal, Air	17	821-0010	4	Screw, Hex Head (1/4-20 x 1/2")
8	122-0345	1	Hose, Oil Drain	18	134-2142	1	Housing, Air - Right
9	508-0162	1	Grommet, Rubber	19	134-2141	1	Housing, Air - Left
10	508-0166	1	Grommet, Rubber	20	134-2330	1	Housing, Blower

FUEL SYSTEM AND EXHAUST GROUP

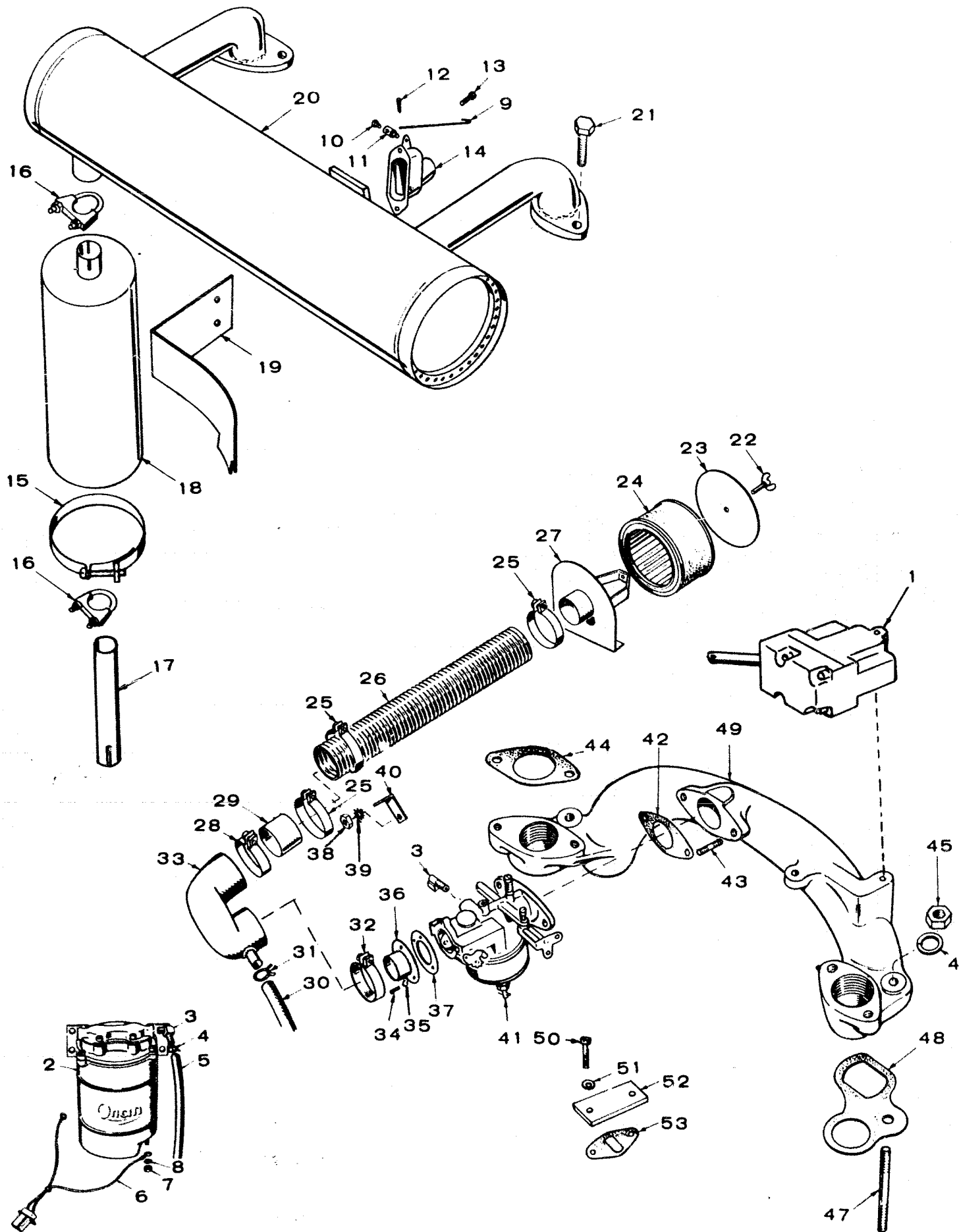

REF. NO.	PART NO.	QTY. USED	PART DESCRIPTION
1	150-1029	1	*Vacuum Booster
2	149-1304	1	*Pump, Fuel
3	502-0313	3	Elbow, 90°
4	503-0301	3	Clamp, Hose
5	503-0728	1	Hose, Fuel
6	338-0892	1	Harness, Wiring
7	860-0008	1	Nut, Hex (8-32)
8	850-0025	1	Washer, Lock (8)
9	153-0443	1	Linkage, Choke
10	815-0104	1	Setscrew (8-32 x 5/16")
11	152-0155	1	Swivel, Linkage
12	516-0059	1	Pin, Cotter
13	815-0261	2	Screw, Hex Head (10-32 x 3/8")
14	153-0223	1	Choke, Electric - Sisson
15	503-0621	1	Clamp, Muffler
16	155-1015	2	Clamp, Muffler
17	155-1195	1	Tube, Exhaust
18	155-1181	1	Muffler, Exhaust
19	155-1188	1	Support, Muffler
20	155-1186	1	Manifold, Exhaust
21	821-0016	4	Screw, Hex Head (5/16-18 x 3/4")
22	518-0056	1	Screw, Wing
23	140-1153	1	Cover, Air Cleaner
24	140-0495	1	Cartridge, Air Cleaner
25	503-0004	3	Clamp, Hose
26	503-0628	1	Hose, Air
27	140-1173	1	Bracket, Air Cleaner
28	503-0851	1	Clamp, Hose

REF. NO.	PART NO.	QTY. USED	PART DESCRIPTION
29	140-1151	1	Tube, Air Inlet
30	503-0486	1	Hose, Air
31	503-0171	1	Clamp, Hose
32	503-0280	1	Clamp, Hose
33	140-1157	1	Elbow, Air Inlet
34	815-0199	3	Screw, Fillister Head (10-32 x 5/16")
35	850-0030	3	Washer, Lock (10)
36	145-0398	1	Adapter, Air Inlet
37	140-0921	1	Gasket, Adapter
38	868-0002	2	Nut, Hex (5-16 x 24)
39	854-0017	2	Washer, Lock, EXT (5-16)
40	140-1150	1	Bracket, Air Hose
41	141-0806	1	*Carburetor, Gasoline
42	141-0281	1	Gasket, Carburetor
43	520-0526	2	Stud, Carburetor Mounting
44	154-1382	2	Gasket, Exhaust Manifold
45	104-0091	2	Nut, Hex (3/8-24) Manifold Mounting
46	850-0050	2	Washer, Lock (3/8)
47	520-0713	2	Stud, Manifold Mounting
48	154-1250	2	Gasket, Engine - Manifold
49	154-1385	1	Manifold, Intake
50	800-0004	2	Screw, Hex Head (1/4-20 x 5/8")
51	526-0063	2	Washer, Flat, Copper (1/4)
52	149-0136	1	Plate, Cover
53	149-0003	1	Gasket, Cover

* - See Separate Group for Components and Service Kits.

CARBURETOR PARTS GROUP

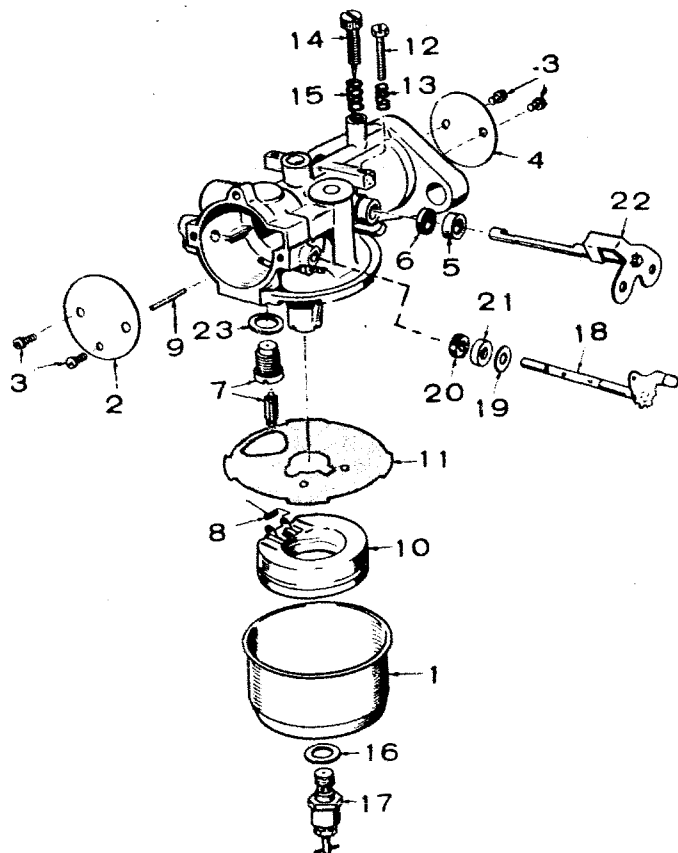

REF. NO.	PART NO.	QTY. USED	PART DESCRIPTION
	141-0806	1	Carburetor, Gasoline
	141-0747	1	Repair Kit (Includes Parts Marked *)
	141-0748	1	Gasket Kit (Includes Parts Marked †)
	141-0281	1	*†Gasket, Carburetor Flange
1	141-0708	1	Bowl, Fuel
2	141-0771	1	Plate, Choke
3	141-0698	4	Screw & Washer, Choke and Throttle Plate Mounting
4	141-0817	1	Plate, Throttle
5	141-0705	1	*Retainer, Seal
6	141-0661	1	*†Seal, Rubber
7	141-0798	1	*Valve Seat Assembly, Fuel
8	141-0799	1	*Spring, Float
9	141-0703	1	*Shaft, Float
10	141-0702	1	Float Assembly
11	141-0701	1	*†Gasket, Bowl to Body
12	141-0700	1	Screw, Throttle Stop
13	141-0711	1	Spring, Throttle Stop
14	141-0713	1	Needle, Idle Adjusting
15	141-0710	1	Spring, Idle Needle
16	141-0077	1	*†Washer, Main Jet Assembly
17	141-0816	1	Jet Assembly, Main, Adjustable
18	141-0742	1	Shaft, Choke
19	141-0699	1	Washer
20	141-0697	1	*†Seal, Felt
21	141-0203	1	*Retainer, Felt Seal
22	141-0709	1	Shaft & Lever, Throttle
23	141-0077	1	†Gasket, Fuel Valve Seat

* - Parts contained in Repair Kit.

† - Parts contained in Gasket Kit.

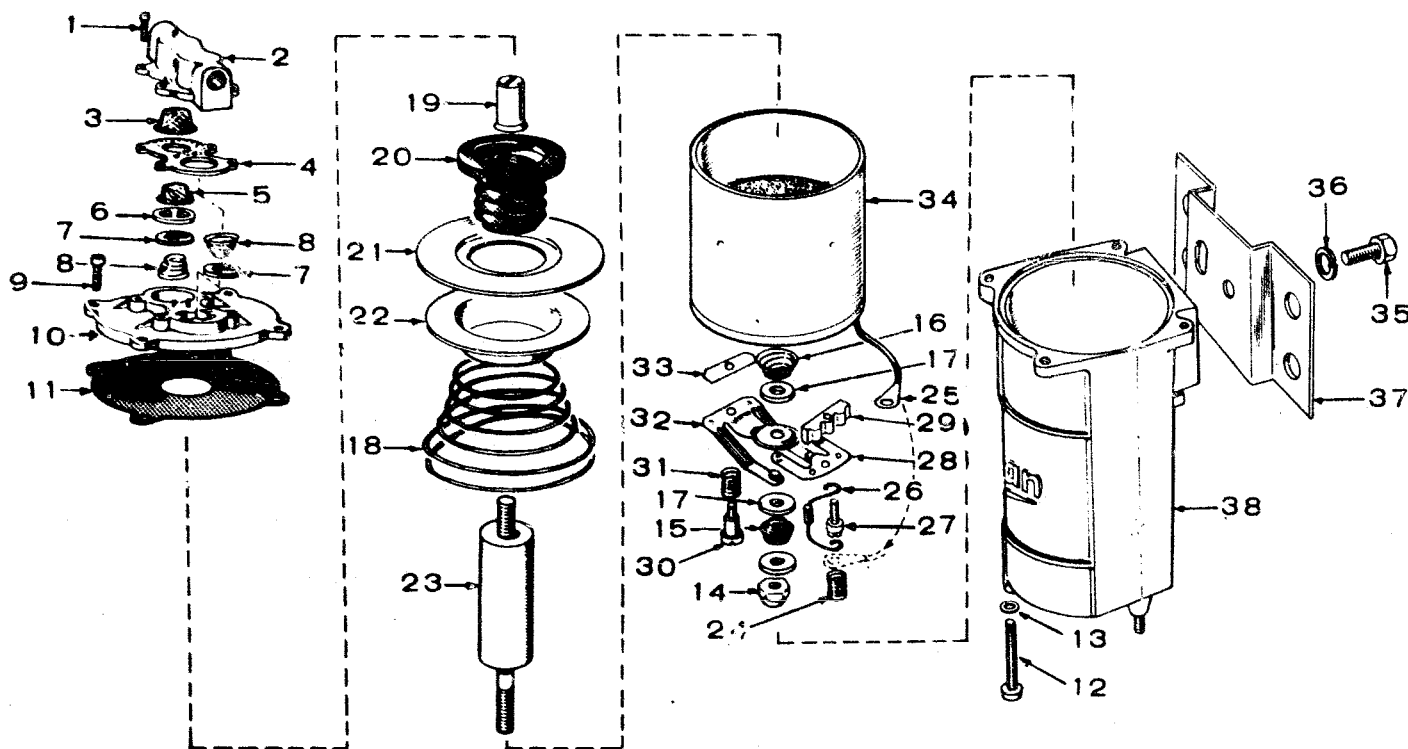

FUEL PUMP GROUP (ELECTRIC)

REF. NO.	PART NO.	QTY. USED	PART DESCRIPTION	REF. NO.	PART NO.	QTY. USED	PART DESCRIPTION
1	149-1304 #	1	Pump, Fuel (Electric)	21	£	1	Plate, Retaining, Bellows
		4	Screw, Fillister Locking	22	£	1	Plate, Retaining, Spring
2	£	1	Valve Cap, Pump	23	£	1	Armature, Fuel Pump
3	149-1397	1	Screen, Filter (7/8" Dia.)	24	*	1	Spring, Helical, Compression (Electrical Connection)
4	149-1399	1	Gasket, Cap to Housing, Valve	25	£	1	Lug, Terminal (Coil Lead)
5	149-1398	1	Screen, Filter (5/8" Dia.)	26	*	1	Diode
6	£	1	Seat, Valve, Pump	27	*	1	Screw, Special, Nylon
7	149-1400	2	Disc, Valve, Pump	28	*	1	Plate, Terminal, Point
8	£	2	Spring, Valve, Pump	29	*	1	Insulator, Spacer
9	#	4	Screw, Fillister Locking	30	*	1	Screw, Binder Head, Slotted, Shoulder, Brass (8-32 x 15/16")
			Head, Cross-Recessed, Steel (8-32 x 3/8")	31	£	1	Spring, Helical, Compression (Point Damper)
10	£	1	Housing, Valve, Pump	32	*	1	Plate Assembly, Breaker Point
11	149-1401†	1	Gasket, Valve Housing to Pump Body	33	*	1	Insulator, Breaker Plate
12	#	2	Screw, Binder Head, Cross-Recessed, Steel (8-32 x 15/16")	34	£	1	Coil Assembly, Fuel Pump
13	#	2	Washer, Flat, Fiber (No. 8)	35	#	2	Screw, Hex Head, Steel (1/4-20 x 1/2")
14	*	1	Nut, Hex, Acorn, Sheet Metal (No. 8)	36	#	2	Washer, Lock, Steel (1/4)
15	*	1	Spring, Helical, Compression (Barrel Shaped)	37	£	1	Bracket, Fuel Pump Mounting
16	*	1	Spring, Helical, Compression (Flat Coil)	38	£	1	Case, Fuel Pump Body
17	*	3	Washer, Insulating, Nylon (No. 8)	149-1395		1	Repair Kit, Point (Includes Parts Marked *)
18	†	1	Spring, Helical, Compression (Bellows Pressure)	149-1396		1	Repair Kit, Bellows (Includes Parts Marked †)
19	†	1	Nut, Retaining, Bellows				
20	†	1	Bellows, Fuel Pump				

£ - Original Equipment Parts, Not Sold Separately; Order Complete Pump for Replacement.

* - Parts Included in Point Repair Kit.

† - Parts Included in Bellows Repair Kit.

- Standard Hardware Parts, Procure Locally.

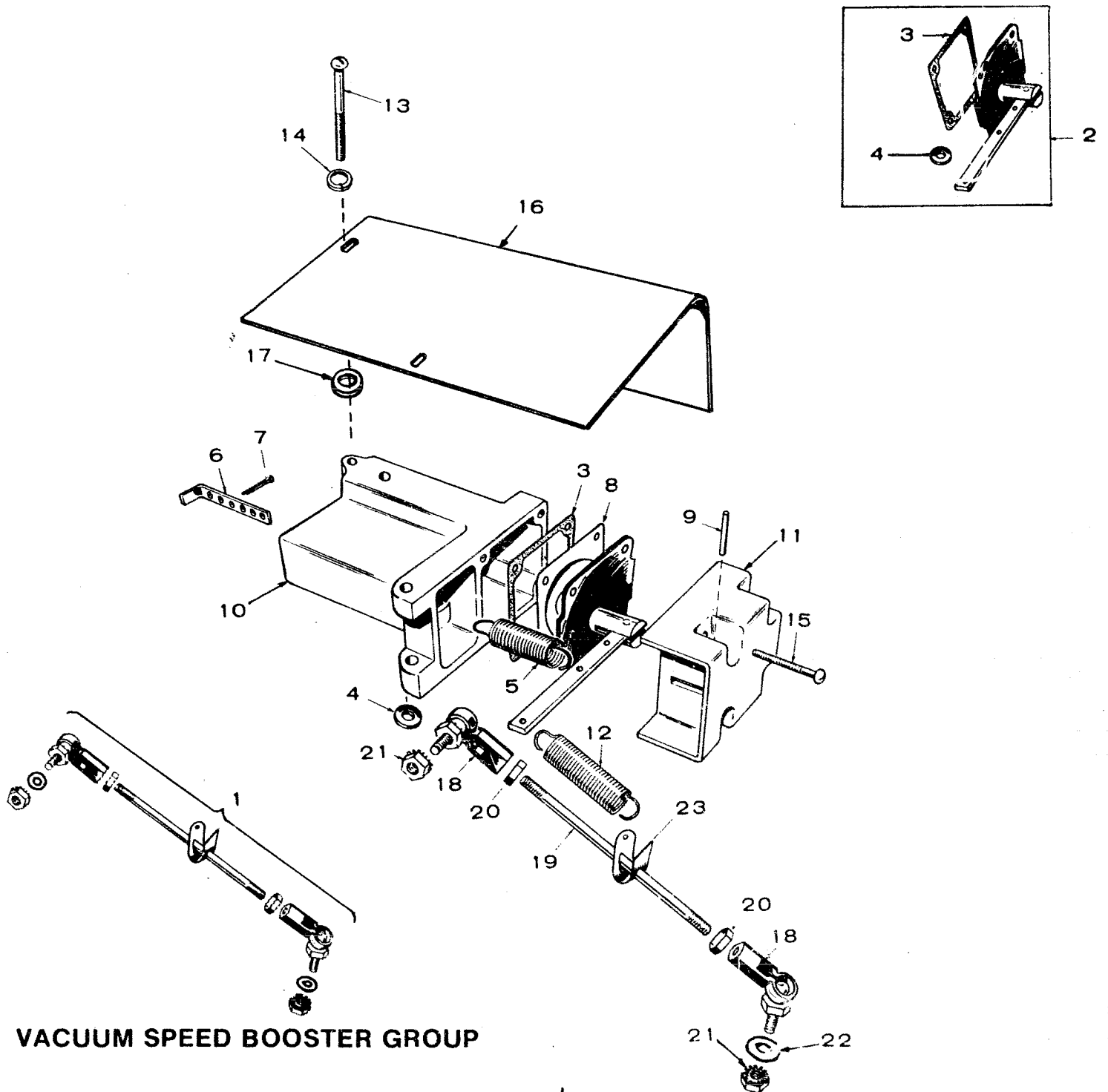

VACUUM SPEED BOOSTER GROUP

REF. NO.	PART NO.	QTY. USED	PART DESCRIPTION	REF. NO.	PART NO.	QTY. USED	PART DESCRIPTION
	150-1030	1	Kit, Vacuum Speed Booster	11	150-0644	1	Cover, Vacuum Booster
1	150-1080	1	Linkage Assembly, (Includes Parts Marked *)	12	150-0471	1	Spring, External
2	150-1031	1	Kit, Diaphragm Replacement, Includes Gaskets	13	813-0111	2	Screw, Round Head (10-02 x 2-1/4") Booster Mounting
3	150-0668	1	Gasket, Diaphragm Plate	14	853-0008	2	Washer, Lock
4	150-0425	1	Gasket, Booster to Manifold	15	815-0148	4	Screw, Hex Head (8-02 x 7/8")
5	150-0475	1	Spring, Internal	16	150-1332	1	Shield, Heat
6	150-0376	1	Bracket, Internal Spring Adjusting	17	526-0196	2	Washer, Spacer - Shield Mounting
7	516-0039	1	Pin, Cotter (3/32 x 5/8") Adjusting Bracket	18	150-0639	2	*Joint Ball
8	150-0666	1	Plate, Diaphragm	19	520-0187	1	*Rod, Linkage
9	516-0085	1	Pin (3/32 x 3/4"), Diaphragm Lever Pivot	20	870-0053	2	*Pinnut
10	150-1355	1	Housing, Vacuum Booster (Not Sold Separately)	21	870-0131	2	*Nut, Keps
				22	526-0196	2	*Washer, Flat
				23	150-0430	1	*Bracket, Spring

* - Parts included in Linkage Assembly.

CONTROL - IGNITION GROUP

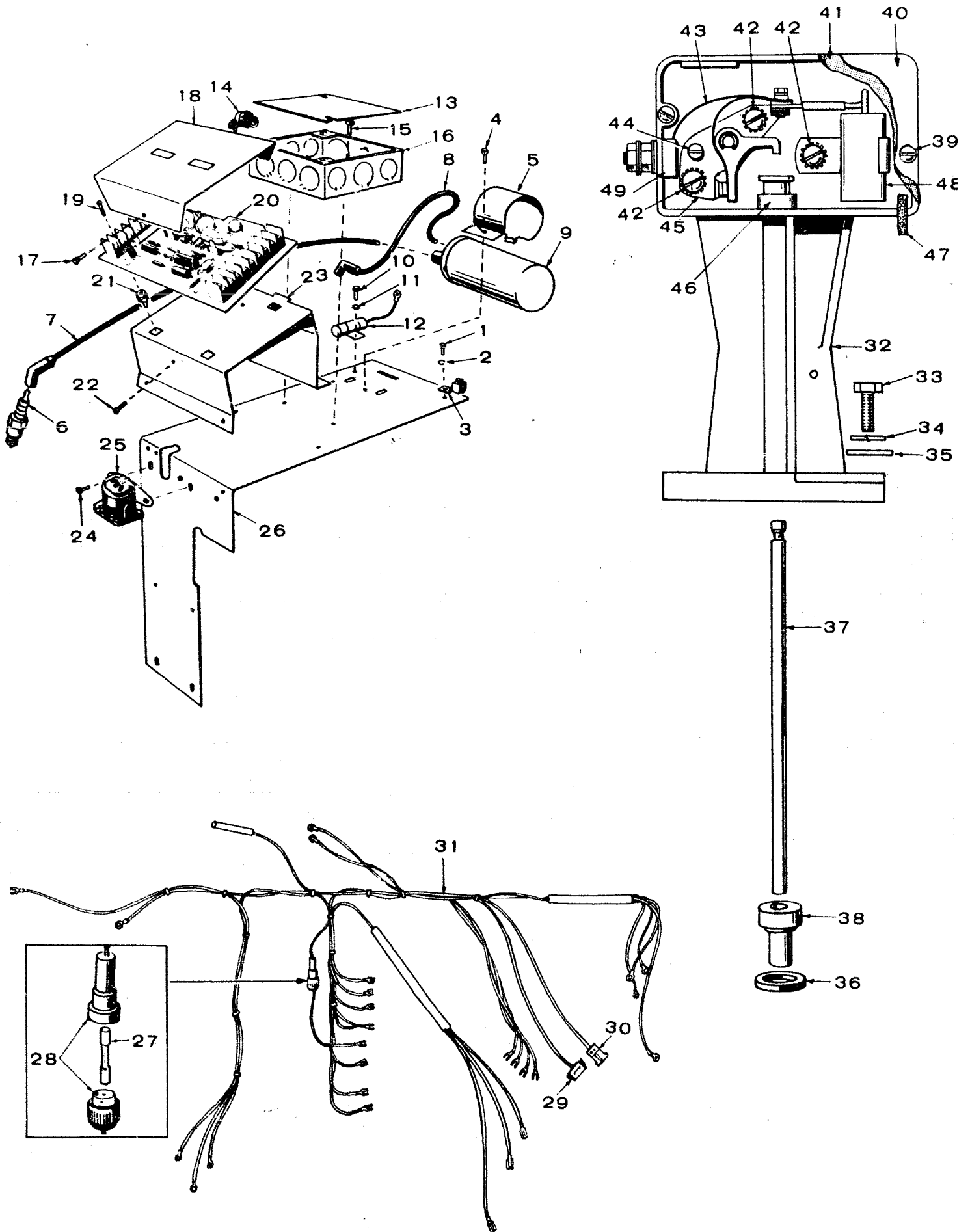

REF. NO.	PART NO.	QTY. USED	PART DESCRIPTION
1	821-0010	1	Screw, Hex Head (1/4-20 x 1/2")
2	856-0006	1	Washer, Lock (1/4)
3	332-0142	1	Terminal, Lug - Solderless
4	815-0350	1	Screw, Hex Head (10-32 x 3/8")
5	166-0588	1	Clamp, Coil
6	167-0242	2	Spark Plug
7	167-1520	1	Cable, Spark Plug (7-1/2")
8	167-1557	1	Cable, Spark Plug (14-1/2")
9	166-0535	1	Coil, Ignition
10	815-0350	1	Screw, Hex Head (10-32 x 3/8")
11	656-0003	2	Washer, Ext (10)
12	312-0027	1	Condenser, Ignition
13	330-0008	1	Cover, Outlet Box
14	508-0179	1	Cable Strain Relief
15	815-0350	2	Screw, Hex Head (10-32 x 3/8")
16	330-0028	1	Box, Outlet
17	815-0350	1	Screw, Hex Head (10-32 x 3/8")
18	301-3484	1	Cover, Control
19	815-0365	4	Screw, Round Head (8 x 3/4") Self-Tapping
20	300-0859	1	Control Board Assembly (See Separate Group for Components)
21	870-0263	4	Nut, Insulator
22	815-0350	4	Screw, Hex Head (10-32 x 3/8")
23	301-3481	1	Bracket, Control Mounting
24	821-0009	2	Screw, Hex Head (1/4-20 x 3/8")
25	307-1166	1	Relay, Solenoid
26	301-3483	1	Bracket, Control Assembly Mounting
27	321-0194	1	Fuse (9 Amp, 32 Volt) (Part of Wiring Harness)
28	321-0193	1	Fuse Holder (Part of Wiring Harness)
29	323-0440	1	Connector, Plug (Part of Wiring Harness)

REF. NO.	PART NO.	QTY. USED	PART DESCRIPTION
30	323-0541	1	Connector, Plug (Part of Wiring Harness)
31	338-0897	1	Harness, Wiring
32	160-1135	1	Breaker Box Assembly (Includes Parts Marked *)
33	802-0035	2	*Screw, Socket Hex Head Cap (1/4-20 x 7/8")
34	850-0040	2	*Washer, Lock (1/4)
35	526-0214	2	*Washer, Flat (1/4)
36	160-1040	1	*Gasket, Box
37	160-0723	1	*Plunger
38	160-1041	1	*Bushing, Plunger
39	812-0077	2	*Screw, Round Head (8-32 x 3/8")
40	160-0930	1	*Cover, Breaker Box
41	160-0150	1	*Gasket, Cover
42	615-0285	3	*Screw, Round Head (8-32 x 5/16)
43	160-0428	1	*Lead, Strap - Point Set
44	160-0075	1	*Cam, Point Adjusting
45	160-0002	1	*Point Set
46	160-0931	1	*Guide, Plunger
47	160-0261	1	*Wick, Breaker Box
48	312-0069	1	*Capacitor, Ignition
49	160-0349	1	*Terminal Block Assembly (Consist of Parts Marked +)
	332-0319	1	+Block, Terminal
	332-0284	1	+Screw, Square Head (10-32 x 3/4")
	508-0016	1	+Washer, Insulating
	508-0017	1	+Washer, Insulating
	526-0049	1	+Washer, Flat - Brass (10)
	854-0010	2	+Washer, Lock (10)
	871-0010	2	+Nut, Hex (10-32)

* - Included in Breaker Box Assembly.
+ - Included in Terminal Block Assembly.

FUEL TANK GROUP

REF. NO.	PART NO.	QTY. USED	PART DESCRIPTION
1	159-1022	1	Tank, 5 Gallon Fuel
2	159-1029	1	Cap & Pickup Assembly Fuel (Includes Parts Marked *)
3	159-1000	1	*Gasket, Fuel Tank Cap
4	159-0990	1	*Cap, Gas Can
5	502-0399	1	*Filter, Ball Check
6	503-0656	1	*Hose, Fuel
7	502-0398	1	*Coupling, Male
8	159-1030	1	*Vent
9	502-0003	1	*Connector, Inverted Male
10	159-0997	1	Line, Fuel - Tank to Pump

* - Included in 159-1029 Fuel Cap & Pickup Assembly.

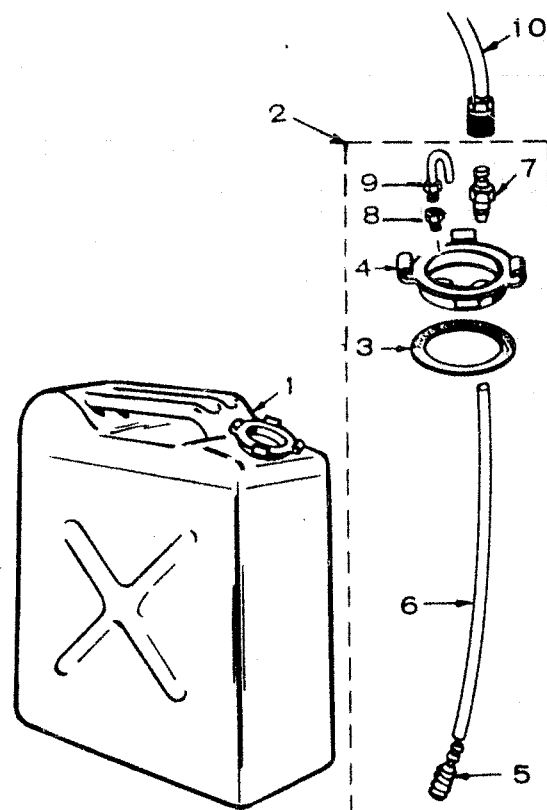

HOUSING GROUP

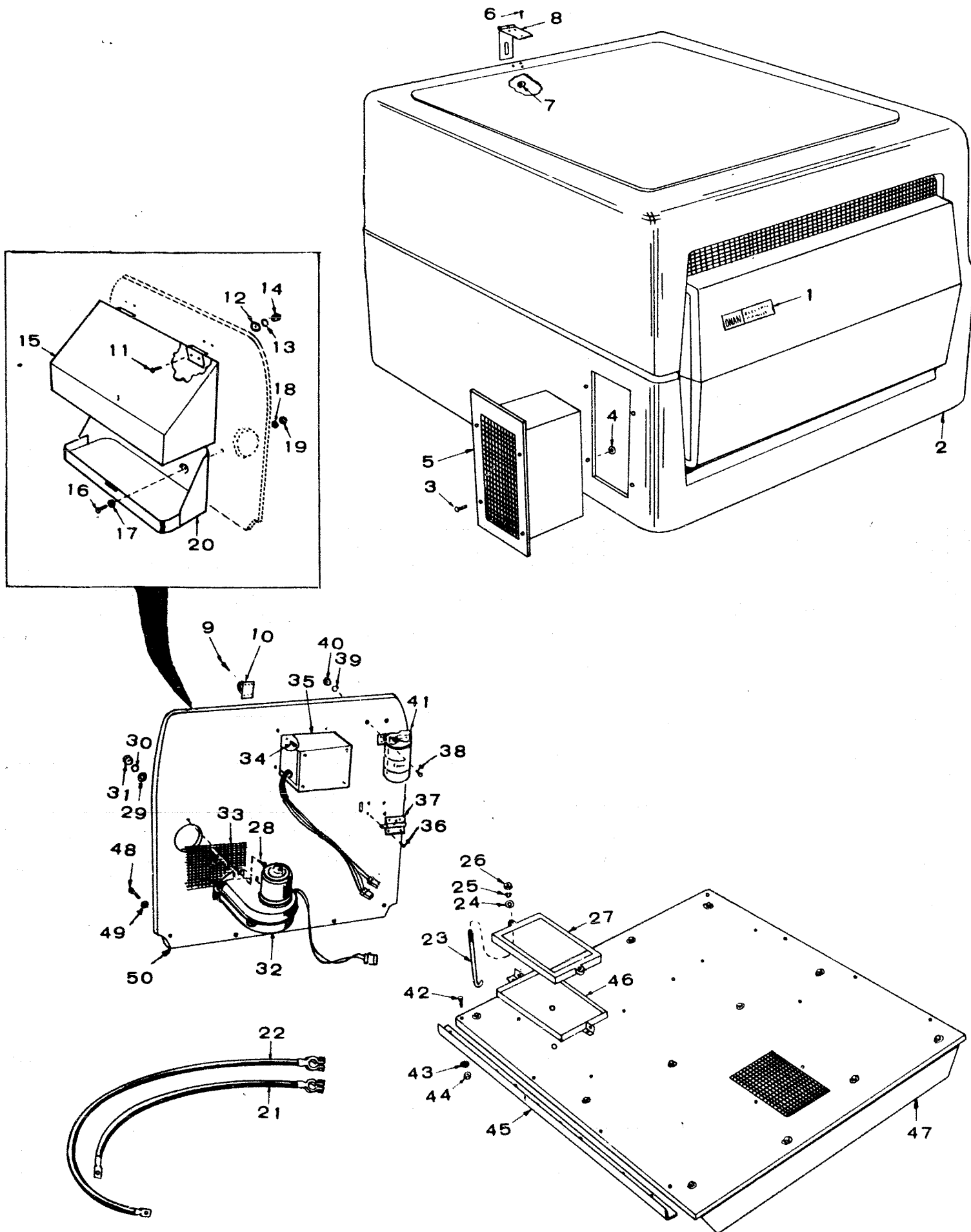

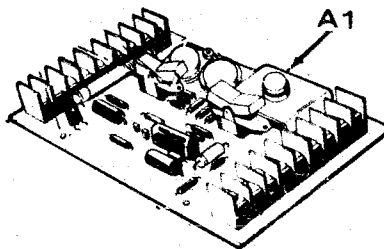
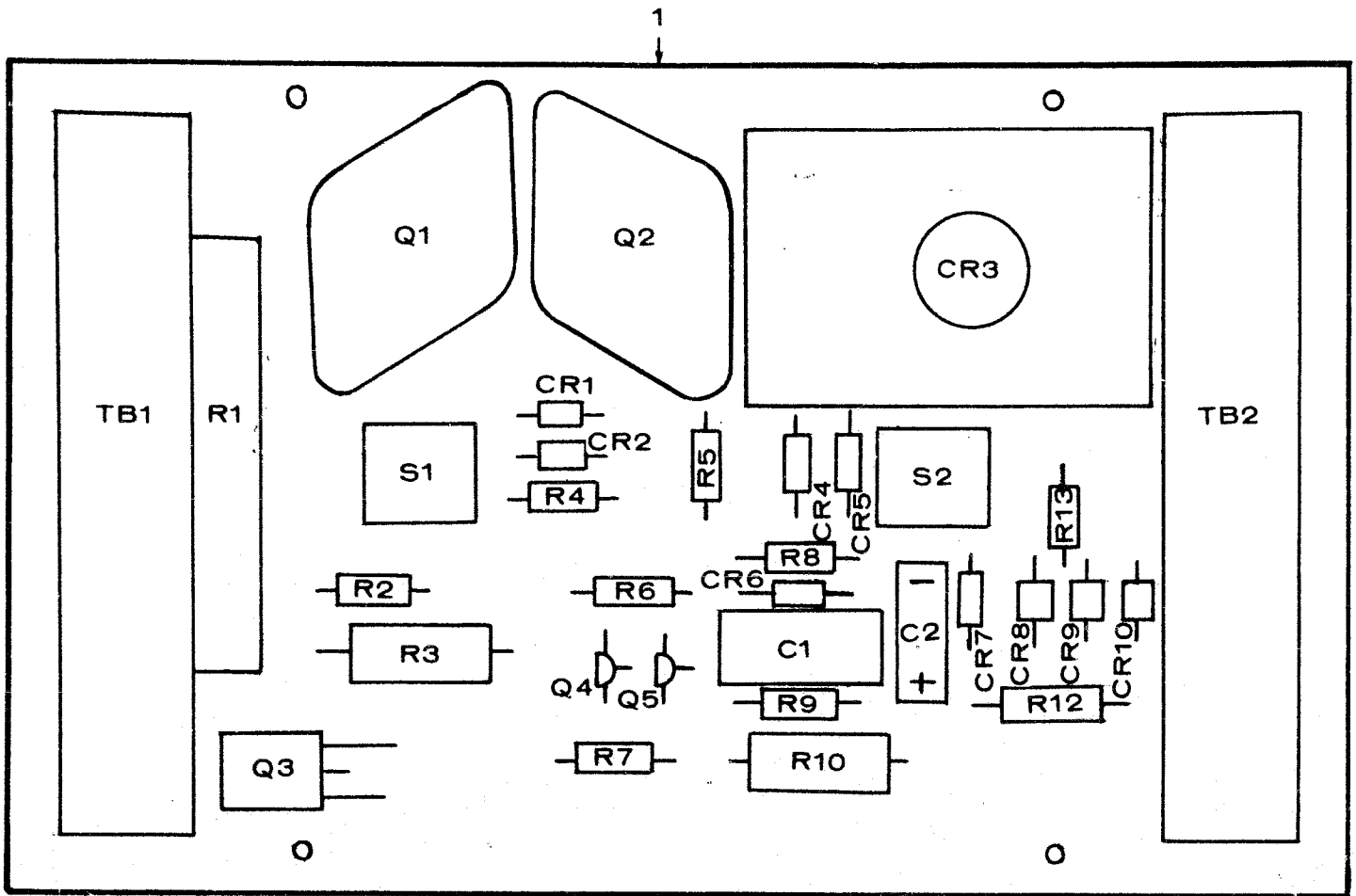

CONTROL ASSEMBLY GROUP 300-0859

REF. NO.	PART NO.	QTY. USED	PART DESCRIPTION	REF. NO.	PART NO.	QTY. USED	PART DESCRIPTION
A1	300-0859	1	Control Assembly	A1R1	353-0043	1	Resistor - 35-Ohm, 10 Watt
A1C1	355-0026	1	Capacitor, .47 Mfd.	A1R2	350-0437	1	Resistor - 120K-Ohm, 1/2 W, 5%
A1C2	356-0046	1	Capacitor, Electrolytic - 5 Mfd.	A1R3	350-0977	1	Resistor - 390-Ohm, 2 W, 5%
A1CR1	357-0013	1	Rectifier	A1R4	350-0427	1	Resistor - 47K-Ohm, 1/2 W, 5%
A1CR2	357-0013	1	Rectifier	A1R5	350-0404	1	Resistor - 5.1K-Ohm 1/2 W, 5%
A1CR3	358-0054	1	Diode and Heat Sink	A1R6	350-0315	1	Resistor - 1-Ohm, 1/2 W, 5%
A1CR4	357-0004	1	Rectifier	A1R7	350-0355	1	Resistor - 47-Ohm, 1/2 W, 5%
A1CR5	357-0004	1	Rectifier	A1R8	350-0379	1	Resistor - 470-Ohm, 1/2 W, 5%
A1CR6	357-0004	1	Rectifier	A1R9	350-0530	1	Resistor - 330-Ohm, 1/2 W, 5%
A1CR7	359-0026	1	Diode	A1R10	350-0983	1	Resistor - 680-Ohm, 2 W, 5%
A1CR8	357-0017	1	Rectifier	A1R12	350-0673	1	Resistor - 270-Ohm, 1 W, 5%
A1CR9	357-0017	1	Rectifier	A1R13	350-0404	1	Resistor - 5.1K-Ohm, 1/2 W, 5%
A1CR10	357-0013	1	Rectifier	A1S1	308-0323	1	Switch - Double Pole, Double Throw
A1Q1	362-0018	1	Transistor	A1S2	308-0320	1	Switch - Double Pole, Double Throw
A1Q2	362-0033	1	Transistor	A1TB1	332-1450	1	Terminal Block
A1Q3	362-0028	1	Transistor	A1TB2	332-1450	1	Terminal Block
A1Q4	362-0011	1	Transistor	1	332-1454	1	Printed Wiring Board
A1Q5	362-0011	1	Transistor				

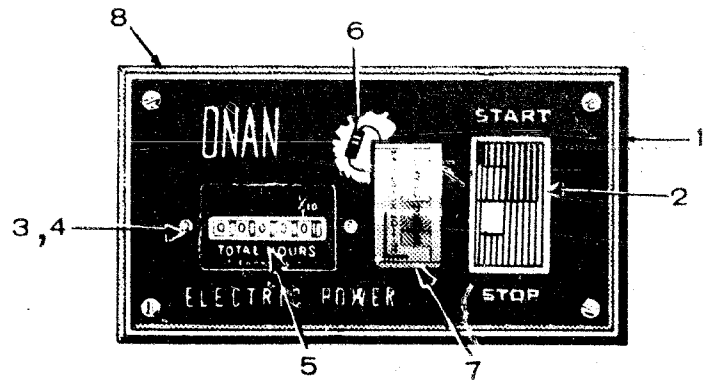
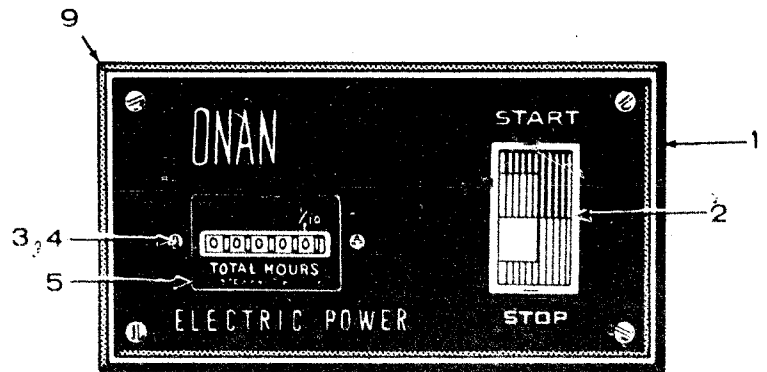
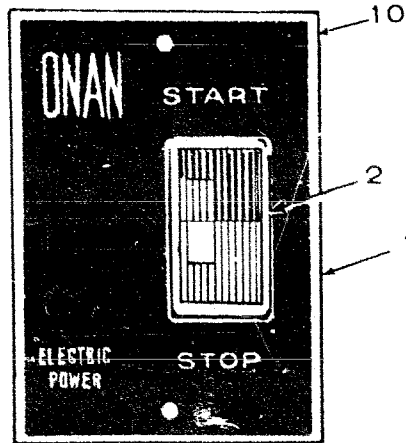

REMOTE STARTING CONTROL GROUP — OPTIONAL EQUIPMENT

REF. NO.	PART NO.	QTY. USED	PART DESCRIPTION
1	CONTROL, REMOTE STARTING (All Parts Marked £)		Include
	300-0985	1	Standard (Also Includes Parts Marked *)
	300-0986	1	Deluxe (Also Includes Parts Marked +)
	300-1131	1	Special (Also Includes Parts Marked †)

REF. NO.	PART NO.	QTY. USED	PART DESCRIPTION
2	308-0341	1	£Switch, Rocker
3	815-0385	2	+†Screw, Round head (6-32 x 1/2")
4	860-0005	2	+†Nut, Hex (6-32)
5	302-0885	1	+†Meter, Time Totalizing
6	359-0034	1	+Diode
7	302-0888	1	+Meter, Battery Condition
8	301-3606	1	+Panel, Control
9	301-3776	1	†Panel, Control
10	301-3566	1	*Panel, Control

£ - Part common to all controls.

* - Part used in Standard Control.

+ - Parts used in Deluxe Control.

† - Parts used in Special Control.

GENERATOR GROUP

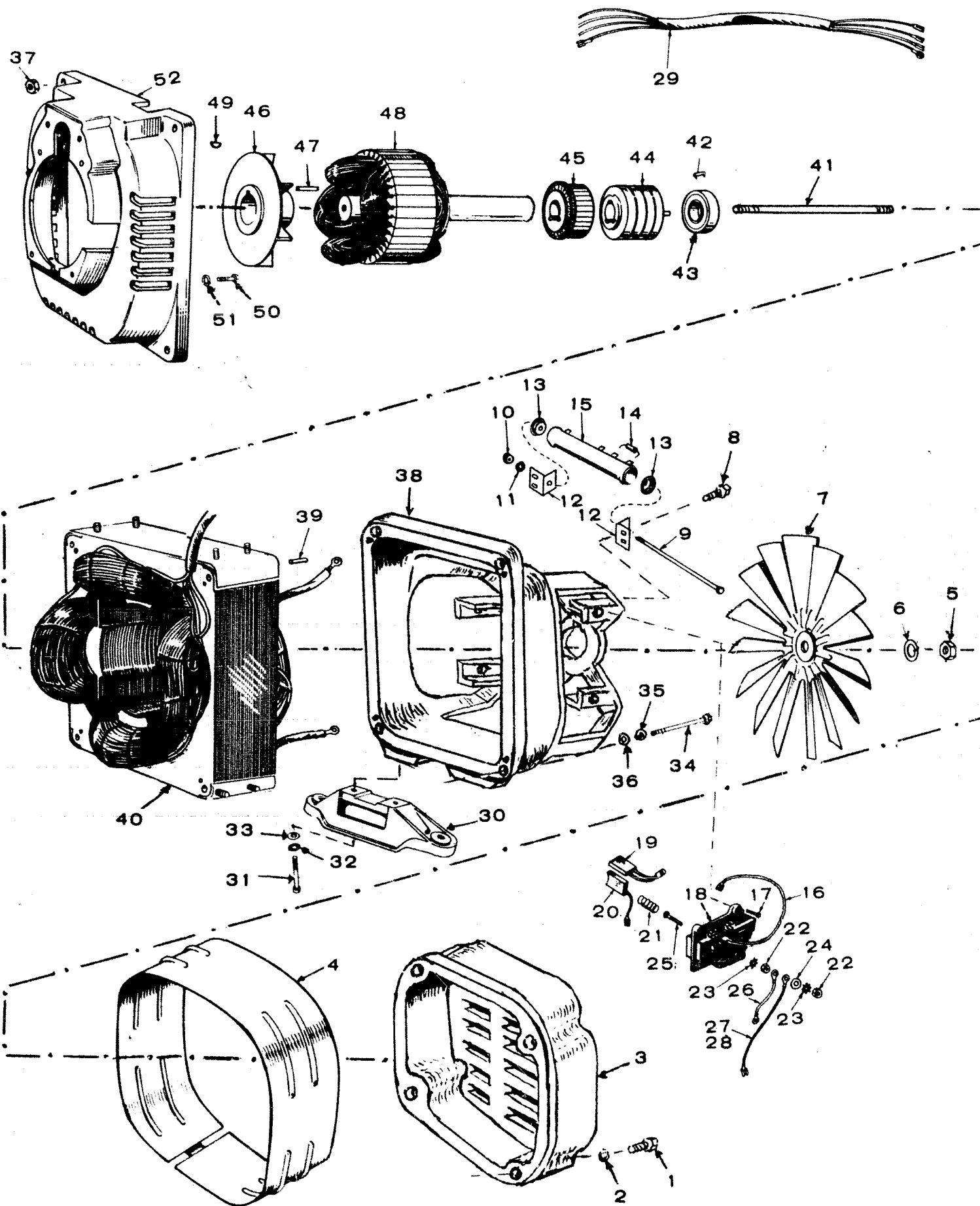

REF. NO.	PART NO.	QTY. USED	PART DESCRIPTION	REF. NO.	PART NO.	QTY. USED	PART DESCRIPTION
1	812-0156	4	Screw, Hex Head (1/4-20 x 1-1/2")	26	336-0186	1	**Lead, Electrical
2	850-0040	4	Washer, Lock (1/4)	27	336-2110	1	+Lead, Electrical
3	232-2107	1	Cover, Generator	28	336-1890	2	*Lead, Electrical
4	234-0362	1	Wrapper, End Bell	29	338-0643	1	Wiring Harness
5	870-0203	1	Nut, Hex (7/16-20)	30	232-2321	1	Support, Generator
6	850-0055	1	Washer, Lock (7/16)	31	800-0051	2	Screw, Hex Head (3/8-16 x 1-1/4")
7	205-0090	1	Fan, Generator	32	850-0050	2	Washer, Lock (3/8)
8	815-0359	2	Screw, Hex Head, Thread forming (10-32 x 7/8")	33	526-0030	2	Washer, Flat (3/8)
9	812-0118	1	Screw, Hex Head (10-24 x 5")	34	800-0044	4	Screw, Hex Head (5/16-18 x 7-1/2")
10	860-0011	1	Nut, Hex (10-24)	35	850-0045	4	Washer, Lock (5/16)
11	850-0030	1	Washer, Lock (10)	36	526-0115	4	Washer, Flat (5/16)
12	304-0706	2	Bracket, Mounting	37	862-0015	8	Nut, Hex (5/16-18)
13	304-0015	2	Washer, Centering	38	211-0187	1	End Bell
14	357-0020	1	Diode Assembly	39	516-0182	8	Pin, Roll
15	353-0047	1	Resistor, Tapped	40	220-1816	1	Stator Assembly
16	336-1891	4	Lead Assembly	41	520-0733	1	Stud
17	815-0359	12	Screw, Hex Head Thread Forming (10-32 x 7/8")	42	232-0596	1	Clip, Bearing Stop
18	BLOCK ASSEMBLY, BRUSH (Each Includes Parts Marked £)			43	510-0047	1	Bearing, Ball (Part of Rotor Assembly)
	212-0345	1	Right (Also Includes Parts Marked +)	44	204-0110	1	Collector Ring (Part of Rotor Assembly)
	212-0352	1	Bottom (Also Includes Parts Marked *)	45	203-0152	1	Commutator (Part of Rotor Assembly)
	212-0346	1	Top (Also Includes Parts Marked *)	46	232-2316	1	Hub, Drive (Part of Rotor Assembly)
	212-0353	1	Left	47	515-0007	1	Key, Drive (Part of Rotor Assembly)
19	214-0095	4	£Brush, Commutator	48	201-1903	1	Rotor Assembly
20	214-0096	8	£Brush, Collector Rings	49	515-0006	1	Key
21	212-1232	12	£Spring, Brush	50	800-0050	4	Screw, Hex Head (3/8-16 x 1-1/4")
22	871-0010	8	£Nut, Hex	51	850-0050	4	Washer, Lock (1/8)
23	853-0008	4	£Washer, Lock	52	231-0164	1	Adapter, Generator to Engine
23	853-0008	1	*Washer, Lock				
24	526-0049	1	*Washer, Flat				
25	815-0341	4	£Screw, Hex Head, Brass (10-32 x 1")				

+ - Parts included in Brush Block 212-0345.

* - Parts included in Brush Block 212-0346.

* - Parts included in Brush Block 212-0352.

£ - Parts included in All Brush Block Assemblies.

SUPPLEMENTARY INSTRUCTIONS AND PARTS LIST

This Supplement applies to the 5.0CCK-3CR/13000 and the 6.5NH-3CR/13000 Home Stand Generator Sets. Use this Supplement with the 927-0360 Operator's Manual and Parts Catalog for the CCK sets and with 940-0360 Operator's Manual and Parts Catalog for the NH sets.

The new models, designated by the Spec Number 13000, are fully automatic for starting and stopping when used with an "Onan" "ET" series Automatic Load Transfer Switch.

INSTRUCTIONS:

The automatic start-stop control includes a trickle battery charging circuit which is used to maintain the starting battery of the generator set. The charge rate is adjustable from 50-300 milliamperes. The control panel includes a milliammeter for state of charge readings. The battery charger consists of a transformer, full wave rectifier and resistors. The trickle charge rate should be set to maintain the unit's battery at full charge. For the first several weeks of operation, the rheostat should be set and the battery condition checked frequently. (Use a hydrometer.) Adjust the charger for a minimum charge rate that will maintain charge condition. Higher rates will shorten battery life. Large ambient temperature changes may require a different charge rate adjustment.

WARNING *FIRST disconnect the battery cables and then remove AC line power to the generator set (remove the "On Utility" fuse F-2 from the ET transfer switch) before performing any maintenance or service. This will eliminate accidental starting of the generator set and prevent a serious shock hazard.*

The Cranking Limiter circuit breaker in the automatic start-stop control de-energizes the generator set starting circuit after 45-90 seconds of cranking time to prevent running batteries down. Reset cranking limiter by pushing in the red button on control housing before cranking is again attempted. The cranking limiter is an electrically-operated thermal relay which protects the engine cranking circuit. The circuit is energized when the engine begins to crank and remains energized until the engine starts. If the engine does not start, a heating element in the limiter opens the cranking circuit after approximately one minute. A one-minute "cool down" period is required before attempting to reset the cranking limiter to start the unit.

NOTE: If repeated attempts to start the set fail, check the fuel supply before resetting the cranking limiter. Lack of fuel will cause the cranking limiter circuit to energize each time set is cranked.

Schematics of the generator set, start-stop control and automatic transfer switch are also included with this supplement.

WARNING *Always use an appropriately sized, approved double-throw transfer switch with any standby generator set. DO NOT PLUG PORTABLE OR STANDBY GENERATOR SETS DIRECTLY INTO A HOUSE RECEPTACLE TO PROVIDE EMERGENCY POWER. It is possible for current to flow from the generator set into the utility line. This creates extreme hazards to anyone working on lines to restore power.*

625-1367

WIRING DIAGRAM

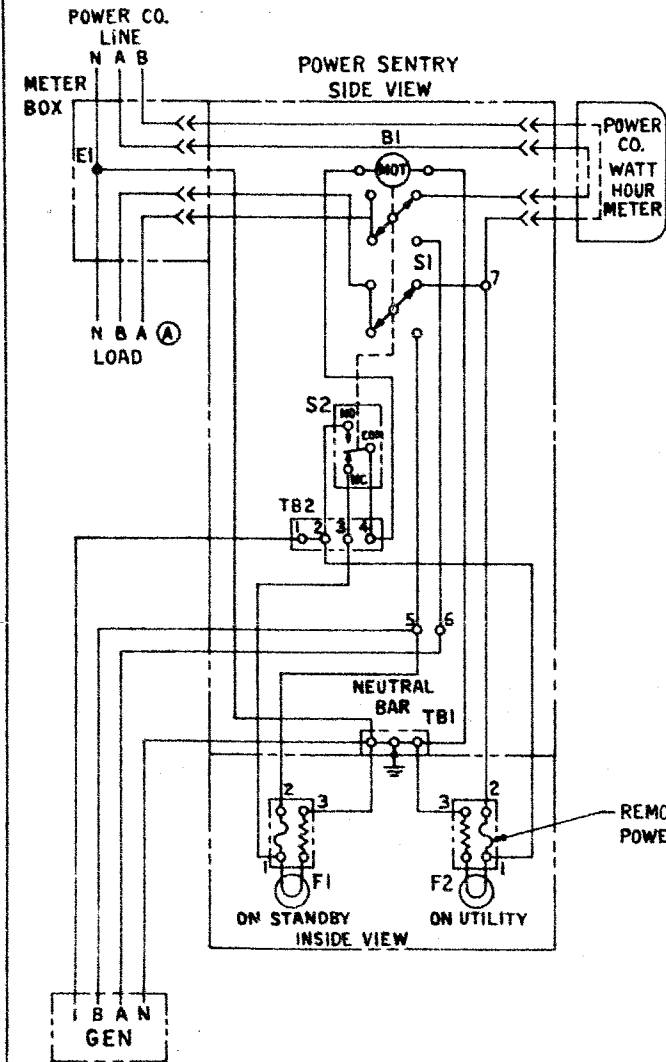

SCHEMATIC

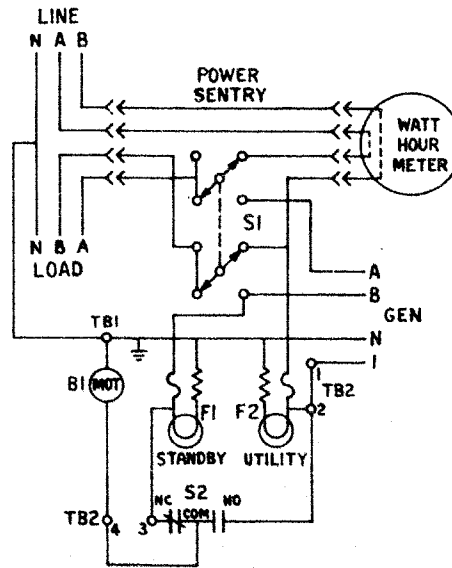

PARTS LIST				
REF	DES	PART NO. (REF)	QTY	DESCRIPTION
		318-0091	1	SWITCH & CONDUIT ASSY (100 AMP)
B1			1	MOTOR
E1			1	CONNECTOR - WIRE
F1,2			1	FUSE HOLDER ASSY
S1			1	SWITCH - POWER SENTRY
S2			1	SWITCH - MICRO
TB1			1	NEUTRAL BAR
TB2			1	TERMINAL BLOCK

625-1367

A REVISED A48 ON LOAD SIDE. W5 1-5-12-75			
LET	REVISION	CR	DATE
 DIVISION OF STUDEBAKER CORPORATION Minneapolis, Minnesota			
MODEL NO	DATE	DR	CR
ETUAP	1-24-75	CDR	W.M.H.
NAME			DWG SIZE
POWER SENTRY (WIRING DIAGRAM)			B
DWG NO.			
625-1367			

PARTS LIST:

The following parts apply to both the CCK and NH Spec 13000 Sets; use these parts in place of/or in addition to those listed in the manuals. Note: Parts that are similar in appearance to those in the manuals are not illustrated. The reference numbers correspond to the numbers in the applicable Group Illustrations in the manual.

CONTROL GROUP

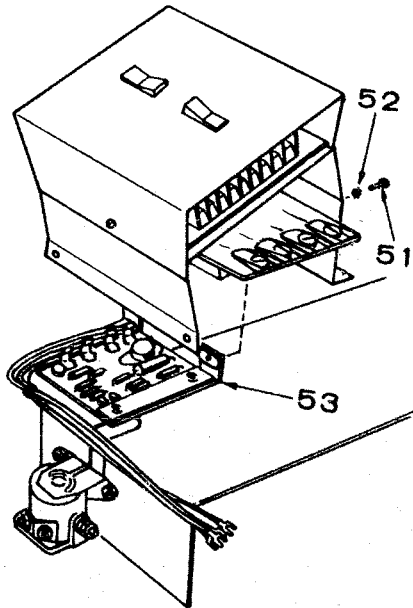

REF. NO.	PART NO.	QTY. USED	DESCRIPTION
51	812-0077	2	Screw, Machine - Round Head (#8-32 x 3/8")
52	853-0005	2	Washer, Lock - External Tooth #8
53	300-1227	1	*Control, Disconnect Adapter (Used beginning with serial #0675954985 during Spec "R" for CCK Sets and during Spec "F" for NH Sets) Optional for use on earlier models.

HOUSING GROUP

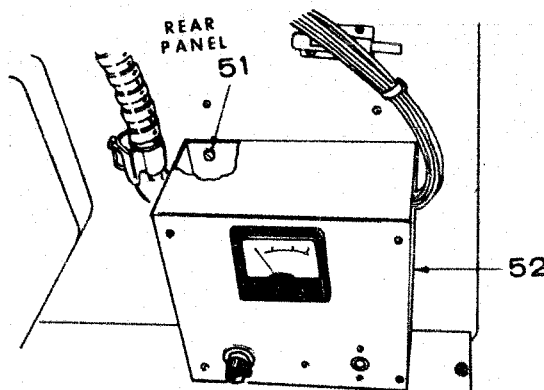

REF.NO.	PART NO.	QTY. USED	DESCRIPTION
51	808-0024	4	Screw, Tapping - Round Head (#8 x 5/8")
52	300-1321	1	*Control, START-STOP - Automatic (Used beginning with SPEC 13000 Models, Optional For earlier models)

* - See Separate Group for Components

AUTOMATIC START-STOP CONTROL GROUP - OPTIONAL EQUIPMENT

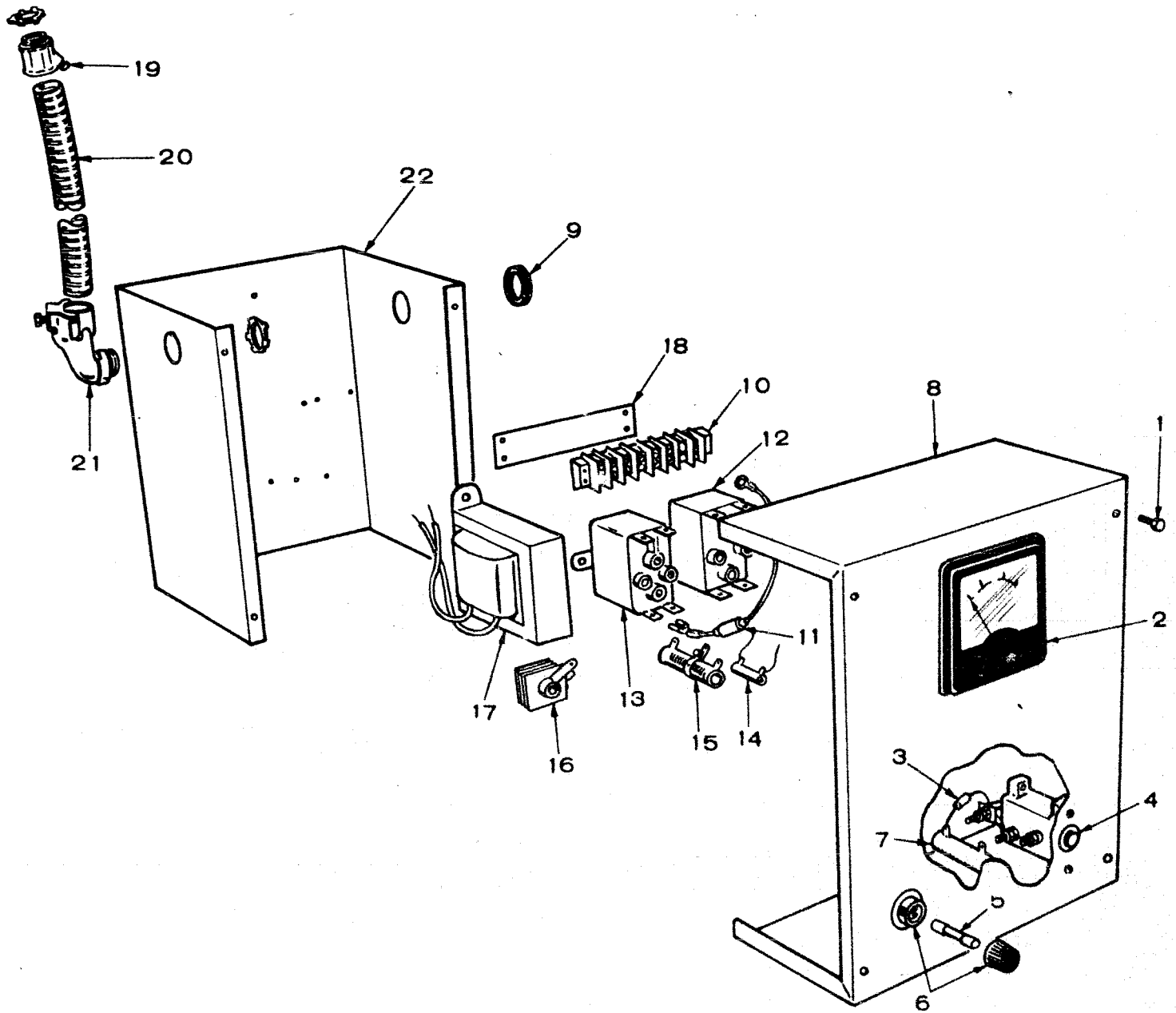

REF. NO.	PART NO.	QTY. USED	DESCRIPTION
1	815-0350	4	Screw, Tapping - Hex Washer Head (#10-32 x 3/8")
2	302-0489	1	Ammeter
3	357-0013	1	Diode, Rectifier
4	320-0104	1	Circuit Breaker - Time Delay (Cranking Limiter)

AUTOMATIC START-STOP CONTROL GROUP - OPTIONAL EQUIPMENT (Continued)

REF. NO.	PART NO.	QTY. USED	DESCRIPTION
5	321-0067	1	Fuse, Cartridge - 1 Amp
6	321-0104	1	Fuse Holder
7	304-0217	1	Resistor, Fixed - 1 Ohm, 10W
8	301-4033	1	Cover, Control Box
9	508-0008	1	Grommet, Rubber
10	332-0699	1	Terminal Block (6 Places)
11	304-0717	1	Resistor, Fixed - 110 Ohm, 1/2 W (With Leads and Terminals)
12	307-1496	1	Relay, Armature - SPDT, 120 VAC, 60 HZ, 8 Amp
13	307-1495	1	Relay, Armature - SPDT, 24 VDC 8 Amp
14	304-0538	1	Resistor, Fixed - 15 Ohm, 5W
15	304-0005	1	Resistor, Adjustable - 0-150 Ohm, 25 W
16	305-0129	1	Rectifier, Selenium - Bridge, 26 VDC, 300 MA
17	315-0009	1	Transformer, Power, Stepdown - 115 to 22 VAC, 12.5 VA, 50/60 Hz
18	332-1925	1	Strip, Marker
19	331-0007	1	Connector, Conduit - Straight (1/2")
20	331-0047	As Req'd.	Conduit, Flexible (1/2")-15" Used
21	331-0010	1	Connector, Conduit - 90° (1/2")
22	301-4028	1	Box, Control

ATTACHING HARDWARE - NOT ILLUSTRATED
(Select as Applicable)

811-0105	As Req'd	Screw, Machine - Round Head Brass (10-32 x 1")
812-0059	As Req'd	Screw, Machine - Round Head (#6-32 x 1/4")
812-0061	As Req'd	Screw, Machine - Round Head (#6-32 x 3/8")
812-0063	As Req'd	Screw, Machine - Round Head (#6-32 x 1/2")
812-0067	As Req'd	Screw, Machine - Round Head (#6-32 x 7/8")
812-0077	As Req'd	Screw, Machine - Round Head (8-32 x 3/8")
812-0087	As Req'd	Screw, Machine - Round Head (#8-32 x 1 1/2")
812-0090	As Req'd	Screw, Machine - Round Head (#8-32 x 2 1/4")
813-0013	As Req'd	Screw, Machine - Round Head (#10-32 x 2-3/4")
850-0025	As Req'd	Washer, Lock - Spring (#8)
850-0030	As Req'd	Washer, Lock - Spring (#10)
853-0008	As Req'd	Washer, Lock - External Tooth (#10)
856-0003	As Req'd	Washer, Lock - External/Internal Tooth #10
526-0003	As Req'd	Washer, Flat (11/64" ID x 3/8" OD x 1/32" THK)
526-0049	As Req'd	Washer, Flat Brass (0.200" ID x 7/16" OD x 1/32") THK
860-0005	As Req'd	Nut, Hex (#6-32)
860-0008	As Req'd	Nut, Hex (#8-32)
861-0008	As Req'd	Nut, Hex (#10-32)
871-0010	As Req'd	Nut, Hex - Brass (#10-32)
508-0033	As Req'd	Washer, Insulating Mica (7/32" ID x 3/4" OD)
304-0014	As Req'd	Washer, Stepped - Resistor Centering

DISCONNECT ADAPTER CONTROL GROUP

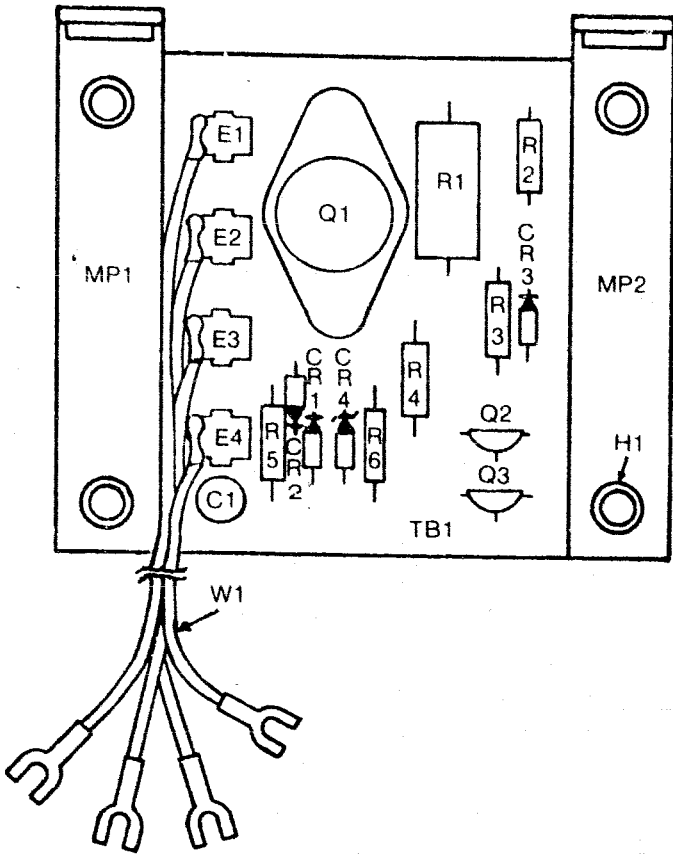

REF. NO.	PART NO.	QTY. USED	PART DESCRIPTION
	300-1227	1	Control, Disconnect Adapter
C1	356-0059	1	Capacitor, 2.2 Mfd 20% 35 vdc
CR1	357-0004	1	Rectifier
CR2	357-0004	1	Rectifier
CR3	357-0004	1	Rectifier
CR4	359-0036	1	Diode
E1-4	332-1511	4	Terminal, Lug
H1	818-0005	4	Rivet, Blind
MP1	332-1656	1	Bracket, Mounting
MP2	332-1656	1	Bracket, Mounting
Q1	362-0035	1	Transistor
Q2	362-0011	1	Transistor
Q3	362-0011	1	Transistor
R1	350-1124	1	Resistor 100-Ohm, 2 Watt, 10%
R2	350-0536	1	Resistor 1000-Ohm, 1/2 Watt, 10%
R3	350-0527	1	Resistor 180-Ohm, 1/2 Watt, 10%
R4	350-0396	1	Resistor 2400-Ohm, 1/2 Watt, 5%
R5	350-0398	1	Resistor 3000-Ohm, 1/2 Watt, 5%
R6	350-0411	1	Resistor 10,000-Ohm, 1/2 Watt, 5%
TB1	332-1833	1	Printed Wiring Board
W1	338-0935	1	Wiring Harness

SPECIAL PARTS LIST FOR MODEL 5.5NH-55CR SPEC 8800 F
 FOR STANDARD PARTS REFER TO CATALOG 940-0360 KEY NO.
 (PARTS CATALOG ALSO CONTAINS COMPONENTS FOR MAJOR OPTIONAL FEATURES LISTED BELOW)
 WIRING DIAGRAM NO. 611-1116-02

PART NO.	QTY.	DESCRIPTION	PART NO.	QTY.	DESCRIPTION
Home Standby					
201-1905	1	Rotor Assembly, Generator			
167-0237	2	Plug, Spark - Resistor			
166-0643	1	Coil, Ignition			
140-1073	1	Clamp, Air Cleaner			
140-1061	1	Cover, Air Cleaner - Top			
140-1071	1	Element, Air Cleaner			
140-1066	1	Cover, Air Cleaner - Bottom			
503-0311	1	Clamp, Hose			
140-1075	1	Elbow, Air Inlet			
140-1067	1	Bracket, Air Cleaner Mounting			

SPECIAL PARTS LIST FOR MODEL 0.5NH-3CR SPEC 8800 F
 FOR STANDARD PARTS REFER TO CATALOG 940-0360 KEY NO. _____
 (PARTS CATALOG ALSO CONTAINS COMPONENTS FOR MAJOR OPTIONAL FEATURES LISTED BELOW)

WIRING DIAGRAM NO. 611-1116-02

PART NO.	QTY.	DESCRIPTION	PART NO.	QTY.	DESCRIPTION
Home Standby					
167-0237	2	Plug, Spark - Resistor			
166-0543	1	Coil, Ignition			
140-1073	1	Clamp, Air Cleaner			
140-1061	1	Cover, Air Cleaner - Top			
140-1071	1	Element, Air Cleaner			
140-1066	1	Cover, Air Cleaner - Bottom			
503-0311	1	Clamp, Hose			
140-1075	1	Elbow, Air Inlet			
140-1067	1	Bracket, Air Cleaner Mounting			